



Proteus

Proteus Brutus FS

The PROTEUS BRUTUS FS is an extremely bright IP66 rated LED Follow Spot fixture offering high intensity and excellent color quality at long distances. Operated manually with removable handles or remotely through one of the many automated remote tracking systems in the market, this purpose build fixture is ideal for any indoor and outdoor application that requires precise and smooth operation, flexible color control and superior output in medium to long throw follow spot applications. The PROTEUS...



ELA0267 | Proteus Brutus FS

Proteus Atlas

The remarkable PROTEUS ATLAS is an extremely powerful and feature-packed IP66 Beam FX fixture with razor-thin 0.6° beam (zoomable to 8.5°) that slices through the night sky in a mesmerizing display visible from vast distances.



ELA0264 | PROTEUS ATLAS

Proteus Radius

The PROTEUS RADIUS is a compact IP66 High Intensity Beam FX fixture. Utilizing an efficient 100W Solid State Phosphor-Converted (SSPC) light engine the fixture projects narrow intense beams with incredible power at long distances. Incredibly fast 360 Degree of Movement on both axis allow impactful beam animations, while the CMY color mix, gobos, prisms and frost options allow the designer to compose an endless array of stunning aerial effects.



ELA0279 | PROTEUS RADIUS

Proteus Hybrid Max

The PROTEUS HYBRID MAX™ combines high output and long lamp life in a feature packed compact IP66 Hybrid fixture. PROTEUS HYBRID MAX is the Extreme Output Hybrid featuring the innovative Philips MSD Platinum FLEX 500 lamp. Rated at 550W and up to 4,000 hours smart lamp life the HYBRID MAX includes CMY and variable CTO plus a full complement of projection and effects options. Four prisms on two planes, dual frosts plus dual gobo wheel and three tracks of animation patterns round...



ELA0271 | PROTEUS HYBRID MAX

Proteus Odeon

The PROTEUS ODEON™ is a powerful yet compact IP66-rated LED profile fixture offering outstanding projection and beam qualities in any environment. Providing up to 32000 lumens output from its custom-designed Variable CRI LED engine, the PROTEUS ODEON is the ideal fixture for any outdoor or indoor application requiring superior output, bright and powerful beams, and quiet operation, as well as stunningly precise gobos and colors. The TruTone variable CRI allows selecting...



ELA0278 | PROTEUS ODEON

Proteus Brutus

The PROTEUS BRUTUS™ is an extremely bright IP65 rated LED Wash FX fixture offering high intensity wash and effects qualities in any environment.



ELA0266 | PROTEUS BRUTUS

Proteus Maximus

The PROTEUS MAXIMUS™ an extremely bright IP65 rated LED Profile fixture offering outstanding projection, beam and wash qualities in any environment.



ELA0275 | PROTEUS MAXIMUS

Proteus Maximus WMG

The PROTEUS MAXIMUS™ WMG is an extremely bright IP65 rated LED Profile fixture offering outstanding projection, beam and wash qualities in any environment. Provided in White Marine Grade (WMG) coating it is designed to withstand the harsh exterior conditions of marine environments found in ship and shore based installations. An optional Hardwire option is available on request.



ELA0276 | Proteus MAXIMUS WMG

Proteus Smarty Hybrid

The Proteus Smarty Hybrid is full featured IP65 certified Spot, Beam and Wash Hybrid fixture for indoor and outdoor use. It features the all new Philips™ MSD Platinum 200 Flex lamp with "FLEX" technology which uses a smartly designed discharge lamp/ballast package to produce high output and compact performance at an efficient, long life solution of up to 6,000 hours.



ELA0286 | PROTEUS SMARTY HYBRID



Proteus Lucius

The PROTEUS LUCIUS™ is a powerful yet compact IP65-rated LED profile fixture offering outstanding projection and beam qualities in any environment.



ELA0343 SIXPAR/20MPLC

Proteus Rayzor Blade S

The PROTEUS RAYZOR BLADE S™ is a striking visual combination of Linear Wash, high intensity Strobe Lines and SparkLED FX inside a compact IP65 linear fixture design. Envisioned to provide the designer unlimited creative control of powerful colors and high-powered strobe effects from a single unit it allows unlimited placement in any outdoor and indoor environment.



ELA0285 PROTEUS RAYZOR BLADE S

Proteus Excalibur

Excalibur is the brightest IP65 fully featured beam fixture ever created with incredible light output from a surprisingly compact fixture body. Rivalling existing Xenon searchlights or skytrackers, the extremely narrow 0.8° Beam ensures the fixture cuts effortlessly through the sky and is visible at great distances.



ELA0269 PROTEUS EXCALIBUR

Proteus Rayzor Blade L

The PROTEUS RAYZOR BLADE L™ is a striking visual combination of Linear Wash, high intensity Strobe Lines and SparkLED FX inside a compact IP65 linear fixture design. Envisioned to provide the designer infinite creative control of powerful colors and high-powered strobe effects from a single unit it allows unlimited placement in any outdoor and indoor environment.



ELA0284 PROTEUS RAYZOR BLADE L

Proteus Rayzor 1960

The PROTEUS RAYZOR 1960™ is a compact yet extremely powerful IP65 rated Wash Effects fixture featuring Elation's unique SparkLED™ system and fast continuous Pan and Tilt motion.



ELA0280 PROTEUS RAYZOR 1960

Proteus Beam WMG

The PROTEUS BEAM WMG™ is an innovative full featured IP65 rated Marine Grade moving head beam luminaire. It features the Philips™ MSD Platinum 14R 280W 80CRI lamp, 7,800K, 12,000 lumens, an advanced optical system producing a precise 2 beam aperture, a revolutionary internal thermal cooling system, true CMY color mixing, high CRI filter, 13 dichroic colors including UV, CTO, CTB and white (open), 8 rotating, interchangeable glass & metal gobos and 13 static-stamped gobos, 5-facet and 32-facet rotating prisms with prism morphing, DMX, RDM (Remote Device Management), Art-NET and sACN (DMX over Ethernet) support, internal E-FLY™ wireless DMX receiver, IP rated 5pin XLR and RJ45 Ethernet in/out connections, IP65 Locking Power cable in, 6 button control full color 180° reversible menu display, 500W max power consumption and a multi-voltage universal auto switching power supply (100-240V).



ELA0265 Proteus Beam WMG

Proteus Rayzor 760

The Proteus Rayzor 760™ is a compact yet extremely powerful IP65 rated Wash Effects fixture featuring Elation's unique SparkLED™ system and fast continuous Pan and Tilt motion.



ELA0281 PROTEUS RAYZOR 760

Proteus Rayzor 760 WMG

The Proteus Rayzor 760 WMG™ is a compact yet extremely powerful IP65 rated Wash Effects fixture featuring Elation's unique SparkLED™ system and fast continuous Pan and Tilt motion. Provided in White Marine Grade (WMG) coating it is designed to withstand the harsh exterior conditions of marine environments found in ship and shore based installations. An optional Hardwire option is available on request.



ELA0282 PROTEUS RAYZOR 760 WMG

Proteus Brutus inkl Framing

The PROTEUS BRUTUS™ is an extremely bright IP65 rated LED Wash Beam FX fixture offering high intensity wash and effects qualities in any environment.

Providing up to 75,000 lumens from its custom designed 1200W Peak Field LED engine the Proteus Brutus is the ideal fixture for any outdoor application requiring superior output, bright and powerful wash, quiet operation as well as stunning colors and effects.



ELA0268 Proteus Brutus inkl Framing

Proteus Hybrid

PROTEUS HYBRID™ is an IP65 rated 3-in-1 hybrid moving head beam, spot, and wash luminaire, with the Philips™ MSD Platinum 21R 470W 80 CRI 8,000K lamp producing over 14,000 lumens. Features include an advanced optical system with motorized zoom from 2° in beam mode to 38° in spot mode or 40° in wash mode, an advanced internal thermal cooling system, full CMY and linear CTO color mixing, 14 dichroic colors including CTB, CTO, and UV, 8 rotating glass interchangeable and 14 static-stamped metal gobos, full 360° bi-directional animation wheel, 8-Facet Circular and 4-Facet Linear rotating prisms and frost filter, motorized focus and auto-focus, high speed mechanical shutter and strobe, DMX, RDM (Remote Device Management), Art-NET, and sACN protocol support, Elation's E-FLY™ internal wireless DMX transceiver, IP rated 5pin XLR and RJ45 ethernet in/out connections, IP65 Locking power cable in, full color 180° reversible menu display with 6 button touch control panel, battery backup for display



ELA0270 | PROTEUS HYBRID

Proteus Hybrid WMG

PROTEUS HYBRID WMG™ is an all white exterior IP65 rated 3-in-1 hybrid moving head beam, spot, and wash luminaire with the Philips™ MSD Platinum 21R 470W 80 CRI 8,000K lamp producing up to 14,000.



Proteus Hybrid WMG HW

PROTEUS HYBRID WMG HW™ is an all white exterior IP65 rated 3-in-1 hybrid moving head beam, spot, and wash luminaire with the Philips™ MSD Platinum 21R 470W 80 CRI 8,000K lamp producing over 14,000 lumens. Features include an advanced optical system with motorized zoom from 2° in beam mode to 38° in spot mode or 40° in wash mode, an advanced internal thermal cooling system, full CMY and linear CTO color mixing, 14 dichroic colors including CTB, CTO, and UV, 8 rotating glass interchangeable and 14 static-stamped metal gobos, full 360° bi-directional animation wheel, 8-facet circular and 4-facet linear rotating prisms and frost filter, motorized focus and auto-focus, high speed mechanical shutter and strobe, DMX & RDM (Remote Device Management) protocol support, fixed IP rated power & data cables, full color 180° reversible menu display with 6 button touch control panel, battery backup for display power, and a multi-voltage universal auto switching power supply (100-240v).



ELA0273 | PROTEUS HYBRID WMG HW

Proteus Maximus WMG HW

The PROTEUS MAXIMUS™ WMG is an extremely bright IP65 rated LED Profile fixture offering outstanding projection, beam and wash qualities in any environment. Provided in White Marine Grade (WMG) coating it is designed to withstand the harsh exterior conditions of marine environments found in ship and shore based installations. An optional Hardwire option is available on request.



ELA0277 | Proteus MAXIMUS WMG HW

Proteus Rayzor 760 WMG HW

The innovative PROTEUS RAYZOR 760 WMG HW™ is available in a white version. The Proteus Rayzor 760™ is a compact yet extremely powerful IP65 rated Wash Effects fixture featuring Elation's unique SparkLED™ system and fast continuous Pan and Tilt motion. With its wide zoom range from 5 to 77 degrees it provides intense and well-defined mid-air beams at over 7,200 lumens as well as an exceptionally wide and even wash coverage, making it a perfect tool for any application, even in adverse outdoor conditions. SparkLEDs offer a prominent and innovative LED pixel effect with dedicated high brightness pixels inside the large front lenses for additional layers of creativity.



ELA0283 | Proteus Rayzor 760 WMG HW

Rebel

REBEL Profile IP

The REBEL Profile™ combines power and versatility in a compact IP65-rated design, perfect for indoor and outdoor applications. Its Peak Field 500W 6,500K LED engine produces a dazzling 22,000 lumens, delivering high-intensity beams, sharp projections, and dynamic mid-air effects.

NEW



A full-featured graphics suite includes 15 glass gobos, a complete animation wheel, dual prisms, dual frost, and a high-speed iris. The indexable framing system ensures precise control with blackout shutter cuts, while a zoom range of 3.5° to 51° enhances its flexibility.

Paragon

PARAGON S

Highly compact, lightweight, and powerful, the PARAGON S™ heralds the future of what's possible in lighting with outstanding projection and beam qualities. Utilizing IP54-rated construction, the Paragon S is ideal for any show or temporary outdoor events, even in the most adverse environments.

NEW



PARAGON M

The PARAGON M™ is a powerful IP54-rated LED profile fixture with outstanding projection and beam qualities in a compact and lightweight form.

NEW







Artiste

Artiste Monet

The award winning Artiste Monet™ is an extremely bright fully featured LED Profile fixture offering outstanding projection quality and a wide color mixing gamut through its variable SpectraColor engine.



ELA0031 | Artiste Monet

Artiste Mondrian

The Artiste Mondrian™ is an extremely bright, full-featured LED profile FX fixture offering high center intensity, narrow-beam angles and a wide color-mixing gamut through its variable SpectraColor engine.



ELA0030 | Artiste Mondrian

Artiste Rembrandt

The Artiste Rembrandt™ is an extremely bright, full-featured LED Wash fixture offering outstanding output, optimized wash field and a wide color-mixing gamut through its variable SpectraColor engine.



ELA0033 | Artiste Rembrandt

Artiste Picasso

The Artiste Picasso™ is a full-featured innovative theatrical-grade luminaire featuring a new 620W 6,800K Cool White LED engine with advanced optics that deliver over 23,000 total lumen output, ultra wide and fast 7° to 55° zoom, a CMY color mixing system producing a range of shades from pastels to rich saturated colors.



ELA0032 | Artiste Picasso

Fuze

Fuze Teatro

The FUZE TEATRO™ is a silent fanless full spectrum automated LED framing fixture designed for theater, television and a wide array of other precision lighting applications.



ELA0113 | Fuze Teatro

Fuze Wash 500 WH

The FUZE WASH 500 WH™ is a powerful automated LED Fresnel wash fixture designed for theater, television, events and a wide array of other precision lighting applications.



ELA0115 | Fuze Wash 500 WH

Fuze Max Profile

The FUZE MAX PROFILE™ is a full spectrum automated LED framing fixture designed for theater, television and a wide array of other precision lighting applications. The 92 CRI engine utilizes an 800W 5-color homogenized LED array consisting of Red, Green, Blue, Mint, and Amber sources.



ELA0094 | FUZE MAX PROFILE

Fuze Max Spot

The FUZE MAX SPOT™ is a full spectrum automated LED Spot fixture designed for theater, television and a wide array of other precision lighting applications. The 92 CRI engine utilizes a 800W 5-color homogenized LED array consisting of Red, Green, Blue, Mint, and Amber sources.



ELA0095 | Fuze Max Spot

Fuze Profile

The FUZE PROFILE™ is an automated LED framing fixture designed for theater, television and a wide array of other precision lighting applications. The 92 CRI engine utilizes a 5-color homogenized LED array consisting of Red, Green, Blue, Mint, and Amber sources.



ELA0109 | Fuze Profile



Fuze Spot

The FUZE SPOT™ is an automated LED spot fixture designed for theater, television and a wide array of other precision lighting applications. The 92 CRI engine utilizes a 5-color homogenized LED array consisting of Red, Green, Blue, Mint, and Amber sources.



ELA0112 | Fuze Spot

Fuze Pendant

The FUZE PENDANT™ provides powerful illumination for a variety of house and area lighting applications. Crisp whites with a high CRI, plus subtle pastels and powerful pure colors with 16-bit dimming, allow for a wide range of smooth illumination and dynamic effects for any environment.



ELA0099 | Fuze Pendant

Fuze Wash FR

The FUZE WASH FR™ is an automated LED Fresnel wash fixture designed for theater, television, events and a wide array of other precision lighting applications. A High-CRI engine utilizes a 5-color homogenized LED array consisting of Red, Green, Blue, Mint, and Amber sources.



ELA0116 | FUZE WASH FR

Fuze Pendant (HW)

The FUZE PENDANT™ (HW) provides powerful illumination for a variety of house and area lighting applications. Crisp whites with a high CRI, plus subtle pastels and powerful pure colors with 16-bit dimming, allow for a wide range of smooth illumination and dynamic effects for any environment.



ELA0107 | Fuze Pendant WH

Fuze Wash 500

The FUZE WASH 500™ is a powerful automated LED Fresnel wash fixture designed for theater, television, events and a wide array of other precision lighting applications. A High-CRI engine utilizes a 5-color homogenized LED array consisting of Red, Green, Blue, Mint, and Amber sources.



ELA0114 | Fuze Wash 500

Fuze Profile CW

The Fuze Profile CW™ is an automated LED framing fixture designed for tradeshow, stages, television and a wide array of AV event applications. The 91CRI 380W engine ensures accurate color reproduction while delivering a powerful output of 11,000 lumens. Designed to illuminate objects like exhibits and banners, texture areas and keylight persons with its flat field and accurate framing, it has many practical applications where a fully automated ellipsoidal fixture is required. A rotating gobo wheel of breakups, two color wheels featuring solid colors and correction filters plus an Iris round out its comprehensive feature set.



ELA0110 | Fuze Profile CW

Fuze SFX

The FUZE SFX™ is a new concept LED Spot FX fixture designed for a variety of applications requiring a compact and powerful multi-purpose luminaire. The SFX is capable of projecting tight beams to wide washes using a highly efficient optical design while providing over 12,000 lumens of output from its 300W white LED engine.



ELA0111 | FUZE SFX

FUZE PFX

The FUZE PFX™ is a unique LED Framing FX fixture designed for a variety of applications requiring a compact and powerful multi-purpose luminaire. The PFX is capable of projecting tight beams, precise framing and wide washes using a highly efficient optical design while providing over 15000 lumens of output from its 400W white LED engine.



Fuze Pendant Compact

The FUZE PENDANT Compact™ provides powerful illumination for a variety of house and area lighting applications. Crisp whites with a high CRI, plus subtle pastels and powerful pure colors with 16-bit dimming, allow for a wide range of smooth illumination and dynamic effects for any environment.



ELA0101 | Fuze Pendant Compact



Accessories

Fuze Wash 500 Motorized Barndoors

The FUZE WASH 500 Motorized Barndoors enhance the fresnel optic with a fully remote-controlled external beam shaping system. The result are smooth defined edges for excellent area control in any application.



| | |
|---------|------------------------------|
| ELA0121 | FW500 Motorized Barndoors |
| ELA0122 | FW500 Motorized Barndoors WH |

Fuze Wash 500 Ovalizer

The FUZE WASH 500 Ovalizer lens creates a rotating oval beam in the projected pattern. The lens is indexable with 16bit accuracy or can rotate continuously for beam effects. It replicates the beam pattern found in traditional incandescent PAR fixtures to allow remote control of the illuminated area. The lens is easy to install onto the front of the fixture with four captive screws, and the DMX layout already contains the lens index control.



| | |
|---------|----------------|
| ELA0123 | FW500 Ovalizer |
|---------|----------------|

Smarty

Smarty Hybrid

The Smarty Hybrid™ is a compact full featured CMY color mixing spot, beam, and wash hybrid luminaire featuring the all new Philips™ MSD Platinum 200 Flex lamp with "FLEX" technology which uses a smartly designed discharge lamp/ballast package to produce high output and compact performance at an efficient, long life solution of up to 6,000 hours.



| | |
|---------|---------------|
| ELA0374 | Smarty Hybrid |
|---------|---------------|

Smarty Max

The SMARTY MAX™ combines high output and long lamp life in a feature packed compact and lightweight Hybrid fixture. SMARTY MAX is the Extreme Output Hybrid featuring the new Philips MSD Platinum FLEX 400 lamp and Elation's 2 year / 4,000 hours Ultimate Warranty.** Rated at 480W and up to 4,000 hours smart lamp life the SMARTY MAX includes CMY and variable CTO and is the world's first Hybrid incorporating a full Iris for dynamic beam effects. Four prisms on two planes, dual frosts plus dual gobo wheel and the unique dual track animation round out the comprehensive FX package in a compact and lightweight housing.



| | |
|---------|------------|
| ELA0375 | Smarty Max |
|---------|------------|

KL

KL Par FC IP

The KL PAR FC IP™ is a compact full-color-spectrum IP65 rated LED fixture that provides high output, precise color temperature control, full-spectrum color rendering, and even wash coverage. Offering powerful color intensity and a wide array of saturated and pastel colors from its efficient RGBMA engine, it is also optimized for the tunable white light requirements of Film and Television.



| | |
|---------|--------------|
| ELA0160 | KL PAR FC IP |
|---------|--------------|

KL CYC S

The KL CYC S is the perfect fixture for smooth and even cyclorama, set and wall washing applications. It utilizes a carefully crafted asymmetrical reflector design to achieve perfect blends while covering significant heights with ease.



| | |
|---------|----------|
| ELA0133 | KL CYC S |
|---------|----------|

KL CYC L

The KL CYC L is the perfect fixture for smooth and evenly illuminated cyclorama, set or wall washing application. It utilizes a carefully crafted asymmetrical reflector design to achieve perfect blends while covering significant heights with ease.



| | |
|---------|----------|
| ELA0132 | KL CYC L |
|---------|----------|

KL Spot IP

The KL SPOT IP™ is an IP65 static LED spot fixture designed for a wide array of precision lighting applications. The 92 CRI engine utilizes a 5-color homogenized LED array consisting of Red, Green, Blue, Mint, and Amber sources. The carefully tuned LEDs ensure accurate color reproduction while delivering a powerful output of over 10,000 lumens. Virtual color temperature, Magenta / Green adjustment provide the designer with immediate access to the impressive LED color array.



| | |
|---------|------------|
| ELA0165 | KL SPOT IP |
|---------|------------|

KL Profile FC

The KL PROFILE FC™ is a manual LED framing fixture designed for a wide array of precision lighting applications. With an integrated manual zoom range of 6 to 50 degrees, the fixture requires no additional lens tubes, reducing cost, complexity and providing excellent flexibility for any theater, performance venue, or show. The integrated manual Iris allows further beam control.



| | |
|---------|---------------|
| ELA0163 | KL PROFILE FC |
|---------|---------------|



KL Par FC

The KL PAR FC™ is a compact full-color-spectrum LED fixture that provides high output, precise color temperature control, full-spectrum color rendering, and even wash coverage. Offering powerful color intensity and a wide array of saturated and pastel colors from its efficient RGBMA engine, it is also optimized for the tunable white light requirements of Film and Television.



| | |
|---------|--------------|
| ELA0158 | KL PAR FC |
| ELA0161 | KL PAR FC WH |

KL Panel

The KL PANEL™ is a full-color-spectrum LED soft light that provides high output, precise color temperature control, full-spectrum color rendering, and even wash coverage. Optimized for the tunable white light requirements of Film and Television, it is an ideal key and fill light source for many situations requiring outstanding performance and color quality.



| | |
|---------|----------|
| ELA0149 | KL PANEL |
|---------|----------|

KL Fresnel 4 FC

The KL FRESNEL 4 FC™ is a full-color-spectrum LED fixture that provides high output, precise color temperature control, full-spectrum color rendering, and even wash coverage. Optimized for the tunable white light requirements of Film and Television, it is an ideal key and fill light source for many situations requiring outstanding performance and color quality, while offering a wide array of rich saturated colors and subtle pastels.



| | |
|---------|-----------------|
| ELA0136 | KL Fresnel 4 FC |
|---------|-----------------|

KL Panel XL

The KL PANEL XL™ is a full-color-spectrum LED soft light that provides high output, precise color temperature control, full-spectrum color rendering, and even wash coverage. Optimized for the tunable white light requirements of Film and Television, it is an ideal key and fill light source for many situations requiring outstanding performance and color quality.



| | |
|---------|-------------|
| ELA0153 | KL PANEL XL |
|---------|-------------|

KL Fresnel 6 FC

The KL FRESNEL 6 FC™ is a full-color-spectrum LED fixture that provides high output, precise color temperature control, full-spectrum color rendering, and even wash coverage. Optimized for the tunable white light requirements of Film and Television, it is an ideal key and fill light source for many situations requiring outstanding performance and color quality, while offering a wide array of rich saturated colors and subtle pastels.



| | |
|---------|-----------------|
| ELA0140 | KL FRESNEL 6 FC |
|---------|-----------------|

KL Panel XL IP

The KL PANEL XL IPT™ is an IP65 full-color-spectrum LED soft light that provides high output, precise color temperature control, full-spectrum color rendering, and even wash coverage. Optimized for the tunable white light requirements of Film and Television, it is an ideal key and fill light source for many situations requiring outstanding performance and color quality.



| | |
|---------|----------------|
| ELA0155 | KL PANEL XL IP |
|---------|----------------|

KL Fresnel 6 FC PO

The KL FRESNEL 6 FC PO™ is a full-color-spectrum LED fixture that provides high output, precise color temperature control, full-spectrum color rendering, and even wash coverage. Optimized for the tunable white light requirements of Film and Television, it is an ideal key and fill light source for many situations requiring outstanding performance and color quality, while offering a wide array of rich saturated colors and subtle pastels.



| | |
|---------|--------------------|
| ELA0141 | KL FRESNEL 6 FC PO |
|---------|--------------------|

KL Fresnel 8

KL FRESNEL 8™ is a 350W 3,000K >96CRI Warm White LED fresnel, producing over 14,000 total lumen output, on par with compatible tungsten halogen models.



| | |
|---------|--------------|
| ELA0143 | KL FRESNEL 8 |
|---------|--------------|

KL Fresnel 8 FC

The KL FRESNEL 8 FC™ is a full-color-spectrum LED fixture that provides high output, precise color temperature control, full-spectrum color rendering, and even wash coverage. Optimized for the tunable white light requirements of Film and Television, it is an ideal key and fill light source for many situations requiring outstanding performance and color quality, while offering a wide array of rich saturated colors and subtle pastels.



| | |
|---------|-----------------|
| ELA0146 | KL FRESNEL 8 FC |
|---------|-----------------|

KL Fresnel 6

KL FRESNEL 6™ is a 150W 3,000K >95CRI Warm White LED fresnel, producing over 6,500 total lumen output, on par with compatible tungsten halogen models.



| | |
|---------|--------------|
| ELA0137 | KL FRESNEL 6 |
|---------|--------------|



KL Fresnel 4

KL FRESNEL 4™ is a 50W 3,000K >97CRI Warm White LED fresnel, producing over 1,900 total lumen output, on par with compatible tungsten halogen models.



ELA0134 | KL FRESNEL 4

KL Fresnel 8 CW

KL FRESNEL 8 CW™ is a 350W 5,600K >97CRI Cool White LED Fresnel, producing over 14,000 total lumen output.



ELA0144 | KL FRESNEL 8 CW

KL Fresnel 6 CW

KL FRESNEL 6CW™ is a 150W 5,600K >97CRI Cool White LED fresnel, producing over 8,500 total lumen output.



ELA0138 | KL FRESNEL 6 CW

KL Fresnel 4 CW

KL FRESNEL 4CW™ is a 50W 5,600K >97CRI Cool White LED fresnel, producing over 2,300 total lumen output.



ELA0135 | KL FRESNEL 4 CW

KL Fresnel 6 CW PO

KL FRESNEL 6CW PO™ is a 150W 5,600K >97CRI Cool White LED fresnel, producing over 8,500 total lumen output.



ELA0139 | KL FRESNEL 6 CW PO

KL Fresnel 6 PO

KL FRESNEL 6PO™ is a 150W 3,000K >95CRI Warm White LED fresnel, producing over 6,500 total lumen output, on par with compatible tungsten halogen models. Features include manual and DMX control, 15° to 38° wide manual zoom, manual and DMX controlled dimmer and shutter. Also, dimmer rotary dial, smooth 16-bit selectable dimming modes and curves, LED refresh rate frequency adjustment for flicker free operation for TV and FILM, removable barn doors (included), RDM (remote device management) protocol support, 3/5pin DMX and IP65 Locking Power Cable in/out connections, 4 button control panel, LCD menu display, multiple unit power linking, a universal auto switching power supply (100-240v), gel frame, rotating barn doors and 28mm Junior Pin / Spigot (included).



ELA0142 | KL FRESNEL 6 PO

KL Fresnel 8 FC PO

The KL Fresnel 8 FC PO is a full-color-spectrum LED fixture that provides high output, precise color temperature control, full spectrum color rendering and even wash coverage. Optimized for the tunable white light requirements of Film and Television, it is an ideal key and fill light source for many situations requiring outstanding performance and color quality, while offering a wide array of rich saturated colors and subtle pastels.



ELA0147 | KL FRESNEL 8 FC PO

KL Fresnel 8 CW PO

KL FRESNEL 8CW PO™ is a 350W 5,600K >96CRI Cool White LED fresnel, producing over 14,000 total lumen output, on par with compatible tungsten halogen models. Features include manual and DMX control, 11° to 56° wide manual zoom, manual and DMX controlled dimmer and shutter. Also, dimmer rotary dial, smooth 16-bit selectable dimming modes and curves, LED refresh rate frequency adjustment for flicker free operation for TV and FILM, removable barn doors (included), RDM (remote device management) protocol support, 3/5pin DMX and IP65 Locking Power Cable in/out connections, 4 button control panel, LCD menu display, multiple unit power linking, a universal auto switching power supply (100-240v), gel frame, rotating barn doors & 28mm Junior Pin / Spigot (included), and a 3 clamp position adjustable mounting yoke.



ELA0145 | KL FRESNEL 8 CW PO



KL Fresnel 8 PO

KL FRESNEL 8 PO™ is a 350W 3,000K >96CRI Warm White LED fresnel, producing over 14,000 total lumen output, on par with compatible tungsten halogen models. Features include manual and DMX control, 11° to 57° wide manual zoom, manual and DMX controlled dimmer and shutter. Also, dimmer rotary dial, smooth 16-bit selectable dimming modes and curves, LED refresh rate frequency adjustment for flicker free operation for TV and FILM, removable barn doors (included), RDM (remote device management) protocol support, 3/5pin DMX and IP65 Locking Power Cable in/out connections, 4 button control panel, LCD menu display, multiple unit power linking, a universal auto switching power supply (100-240v), gel frame, rotating barndoors & 28mm Junior Pin / Spigot (included).



ELA0148

KL FRESNEL 8 PO

KL PAR IP Compact

Compact, powerful, and versatile, the KL PAR IP COMPACT delivers exceptional lighting performance in a small, rugged package. Designed for any environment, this IP65-rated LED fixture offers precise color temperature control, full-spectrum rendering, and consistent wash coverage, powered by a highly efficient RGBMA engine that provides up to 5,474 lumens.

Its advanced ColourTune Technology delivers exceptional color accuracy (CRI 94.9, TLCI 95), 16-bit variable CCT control, and adjustable LED refresh frequency, making it perfect for film, television, and live events. With multiple lens options, DMX/RDM compatibility, and a touch bar encoder for instant adjustments, it's ready for any production need.

Streamline your lighting setup and discover how the KL PAR IP COMPACT can elevate your next production.



KL PROFILE FC Compact

Designed for precision and performance, the KL PROFILE COMPACT brings unparalleled flexibility to any venue, utilizing a compact form factor that delivers exceptional results across diverse applications with vivid color and outstanding quality.

It's advanced optical engineering, combined with integrated 25–50-degree manual zoom and premium lens coatings, ensures sharp, flawless projections free from color shifts or aberrations, regardless of the zoom, focus, or framing position.

Powered by Elation's ColourTune Technology and boasting a CRI of 94.9 and TLCI of 95., the fixture achieves superb color accuracy with 16-bit variable CCT control. Coupled with the ultra-quiet Mute Mode for silent functionality, the KL PROFILE COMPACT redefines precision lighting for theaters, performance venues, and live events, allowing designers to perform brilliantly and broadcast their creative vision.



KL CORE IP

KL CORE IP

The KL CORE IP LED engine offers nearly endless functionality in a rugged and adaptable design. Central to the performance of the device is its high-output, 400W Full-Spectrum LED that is capable of



delivering over 15,000 lumens of output.







KL CORE IP Shutter Barrel

Convert your KL CORE IP into a standard ellipsoidal fixture with the KL CORE IP Shutter Barrel. This versatile accessory is compatible with any industry-standard lens tube and includes both a standard gobo slot and a larger accessory slot, accommodating gobo rotators and other devices with ease. Built to endure the toughest conditions, it features a durable C4 Marine Coating and stainless steel framing shutters, ensuring reliable performance in any environment, indoors or outdoors.



KL CORE IP Fresnel Lens

Experience unmatched versatility with the KL CORE IP Fresnel Lens, designed to elevate the performance of your KL CORE IP fixture. This zooming Fresnel lens delivers soft, uniform light distribution with exceptional light transmission efficiency, ensuring optimal performance in any setting. With a broad zoom range of 10°- 45°, it provides ultimate flexibility for diverse lighting applications. The robust C4 Marine Coating ensures the lens is built to withstand any environment—indoors or outdoors—making it the ideal choice for demanding conditions.



KL CORE IP Bowens Mount

Unlock the flexibility of the KL CORE IP with the KL CORE IP Bowens Mount. This versatile adapter transforms the KL CORE IP engine into a Lamphead or Monolight device, expanding its compatibility with a wide range of beam-shaping accessories.



SÅÆL

SL I Blinder

Using simple fixture interconnects, threaded adapters, mounts and yoke accessories, designers can effortlessly link SL I Blinder to other fixtures or devices, exponentially expanding creative options for unique shapes and arrays. Use it as a single-cell, 2- or 4-cell blinder or connect even more fixtures together for a versatile effects panel that is perfect for eye-candy looks. Create linear blinder arrays, single or multi-unit pendants, custom shapes, and more.



ELA0393 | S?L I Blinder

SL II Blinder

Key Features: 2x 350W RGLAW LED, 30,750 Total Fixture Lumen Output (Sphere), 46° Beam Angle, Simple 'Array Mode' Addressing System, Individual Pan Adjustment with Lock, Dim-to-Warm/ Red Shift Emulation, High Output Blinder Mode or Constant Output Mode Options, Unique Horizontal and Vertical Array Rigging Method (Compatible with SL IV, SL I Blinder Frame, Pulse Panel, SIX+ BAR and PULSE BAR Interconnect), IP65 Rated



ELA0400 | S?L II Blinder

SL IV Blinder

Key Features: 4x 350W RGLAW LED, 59,830 Total Fixture Lumen Output (Sphere), 46° Beam Angle, Simple 'Array Mode' Addressing System, Individual Pan Adjustment with Lock, Dim-to-Warm/ Red Shift Emulation, High Output Blinder Mode or Constant Output Mode Options, Unique Horizontal and Vertical Array Rigging Method (Compatible with SL II, SL I Blinder Frame, Pulse Panel, SIX+ BAR and PULSE BAR Interconnect), IP65 Rated.



ELA0401 | S?L IV Blinder

SOL I BLINDER FRAME



ELA0394 | SOL I BLINDER FRAME

SOL/PULSE HD YOKE



ELA0403 | SOL/PULSE HD YOKE



DTW

DTW Blinder 350 IP

The IP65 rated DTW Blinder 350 IPT[™] features (2) high powered 175W 2-in-1 Warm White / Amber COB LEDs, 65° wide beam angle, full color temperature range control plus independent Dim-to-Warm channel control (1,800K - 3,200K), easily attachable 15° narrow beam filters (included), pixel control, manual adjustable pan focus, variable dimming curve modes, strobe effects, flicker free operation for TV and Film, RDM (Remote Device Management), IP rated DMX and IP65 Locking Power Cable in/out connections, LCD menu display with 4 touch button control panel, integrated yoke and side mounting brackets, and a multi-voltage universal auto switching power supply (100-250v).



ELA0073 DTW Blinder 350 IP

DTW Blinder 700 IP

The IP65 rated DTW Blinder 700 IPT[™] features (4) high powered 175W 2-in-1 Warm White/Amber COB LEDs, a wide 67° beam angle, full color temperature range control plus independent Dim-to-Warm channel control (1,800K - 3,200K), easily attachable 15° narrow beam filters (included), pixel control, manual adjustable pan focus, variable dimming curve modes, strobe effects, flicker free operation for TV and Film, RDM (Remote Device Management), IP rated DMX and power in/out connections, LCD menu display with 4 touch button control panel, integrated yoke and side mounting brackets, and a multi-voltage universal auto switching power supply (100-250v).



ELA0074 DTW Blinder 700 IP

Pulse Bar S

Measuring half a meter in length, the PULSE BAR S incorporates 480 1.5W RGB LEDs distributed across 20 zones along its perimeter. Additionally, it features a central strobe line equipped with 200 5W cool-white LEDs across 20 zones, complemented by 80 1.5W RGB LEDs arranged in 10 zones at its core. When combined, these components deliver an output exceeding 13,327 total lumens.

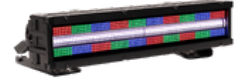

ELA0292 Pulse Bar S

Pulse Bar L

Measuring a meter in length, the PULSE BAR L incorporates 960 1.5W RGB LEDs distributed across 40 zones along its perimeter. Additionally, it features a central strobe line equipped with 400 5W cool-white LEDs across 40 zones, complemented by 160 1.5W RGB LEDs arranged in 20 zones at its core. When combined, these components deliver an output exceeding 25,191 total lumens.



ELA0291 Pulse Bar L

Paladin

Paladin Cube

The PALADIN CUBE[™] is a compact and powerful outdoor floodlight for a wide variety of applications. Using 9x15W RGBW cells it provides a total output of up to 3,200 lumens. Certified to IP65 it features a rugged design with a solid build quality, eliminating the need to worry about dust and water ingress.



ELA0197 PALADIN CUBE

Paladin Brick

The PALADIN BRICK[™] is a compact and powerful outdoor flood light for a wide variety of applications. Using 24x15W RGBW cells it provides a total output of up to 8,200 lumens. Certified to IP65 it features a rugged design with a solid build quality, eliminating the need to worry about dust and water ingress. IP rated connections make it an ideal product to illuminate large areas of any outdoor event with vibrant and powerful colors. It can be operated standing on the floor or be hung in any orientation using the provided omega brackets. Available cell control and strobe features make the PALADIN BRICK also a versatile effects fixture or audience blinder.



ELA0189 PALADIN BRICK

Pulse

Pulse Panel FX

Merge explosive strobe power with visual creativity and dynamic movement with the PULSE PANEL FX. A highly versatile and expressive fixture in the innovative Pulse line of strobe lights, the PULSE PANEL FX adds a burst of dynamism and inspiration to any show.



ELA0294 Pulse Panel FX

Pulse Panel

The PULSE PANEL features the same LED layout found on the Pulse Panel FX. 1,152 1.5W RGB LEDs spread across 24 zones around its perimeter, arranged in a grid of 6 zones wide and 4 zones tall. In addition to this, it includes a central strobe line comprising 288 5W cool-white LEDs organized into 24 zones, with 12 zones across and 2 zones tall.



ELA0293 Pulse Panel



Paladin Panel

The PALADIN PANEL™ is a compact and powerful outdoor floodlight for a wide variety of applications. Using 50x15W RGBW cells it provides a total output of up to 20,000 lumens. Certified to IP65 it features a rugged design with a solid build quality, eliminating the need to worry about dust and water ingress. IP rated connections make it an ideal product to illuminate large areas of any outdoor event with vibrant and powerful colors. It can be operated standing on the floor or be hung in any orientation using the provided omega brackets. Available cell control and strobe features make the PALADIN PANEL also a versatile effects fixture or audience blinder.



ELA0203 | PALADIN PANEL

Six+

Six+ Par S

The SIX+ PAR S is a compact and rugged LED fixture that features (7) 20W RGBLA+UV LED's, which produce an ultra-wide color spectrum and high quality of light while still offering up to 4,570 lumens of output. The optical system has been carefully engineered to offer an even distribution of light and color homogenization within the beam. This fixture has been designed to offer ultimate flexibility, use it indoors or out, it's IP65 rating can handle any environment, and with it's C4-M marine grade coating, it's even safe in harsh costal environments.



ELA0308 | Six+ Par S

Six+ Par L

The SIX+ PAR L is a compact and rugged LED fixture that features (14) 20W RGBLA+UV LED's, which produce an ultra-wide color spectrum and high quality of light while still offering up to 7300 lumens of output. The optical system has been carefully engineered to offer an even distribution of light and color homogenization within the beam. This fixture has been designed to offer ultimate flexibility, use it indoors or out, it's IP65 rating can handle any environment, and with it's C4-M marine grade coating, it's even safe in harsh costal environments.



ELA0307 | Six+ Par L

Six+ Bar S

Equipped with 20W RGB+Lime+Amber+UV LEDs and boasting an impressive CRI of 90.9, the SIX+ BAR S offers a stunning array of colors, ensuring a beautifully homogenized wash of light with high-quality color reproduction. Its meticulously engineered optical system ensures even light distribution, and the proprietary RGBLA+UV engine delivers high-fidelity whites and intense primaries with no color fringing. Extra-large 50 mm lenses make it ideal for direct view applications and individual cell control opens up for a myriad of design possibilities.



ELA0306 | Six+ Bar S

Six+ Bar L

Equipped with 20W RGB+Lime+Amber+UV LEDs and boasting an impressive CRI of 92.3, the SIX+ BAR L offers a stunning array of colors, ensuring a beautifully homogenized wash of light with high-quality color reproduction. Its meticulously engineered optical system ensures even light distribution, and the proprietary RGBLA+UV engine delivers high-fidelity whites and intense primaries with no color fringing. Extra-large 50 mm lenses make it ideal for direct view applications and individual cell control opens up for a myriad of design possibilities.



ELA0305 | Six+ Bar L

Shaders

Shader for Paladin Brick

This shader installs in seconds onto your Paladin Brick unit, giving you further control of the light distribution.



ELA0301 | Shader for Paladin Brick

Shader for Paladin Panel

This shader installs in seconds onto your Paladin Panel unit, giving you further control of the light distribution.



ELA0302 | Shader for Paladin Panel

Shader Paladin for Cube

This shader installs in seconds onto your Paladin Cube unit, giving you further control of the light distribution.



ELA0303 | Shader Paladin for Cube



SixPar

| | |
|--|------------|
| SixPar 100 | |
| <p>The indoor version SIXPAR 100™ features (7) 12W 6-IN-1 RGBAW+UV LEDs, 15° beam and 25° field angles, electronic strobe and dimming (0-100%), 5 variable dimming curve modes, dual yoke / floor stand, multiple unit power linking, RDM (remote device management), rugged die-cast aluminum exterior, flicker free operation for TV and FILM, and a multi-voltage universal auto switching power supply (110-250v).</p> | |
| ELA0322 | SixPar 100 |

| | |
|--|--------------|
| SixPar 100IP | |
| <p>The IP65 rated SIXPAR 100IP™ features (7) 12W 6-IN-1 RGBAW+UV LEDs, 15° beam and 25° field angles, electronic strobe and dimming (0-100%), 5 variable dimming curve modes, dual yoke / floor stand, multiple unit power linking, RDM (remote device management), rugged die-cast aluminum exterior, flicker free operation for TV and FILM, and a multi-voltage universal auto switching power supply (110-250v).</p> | |
| ELA0323 | SixPar 100IP |

| | |
|---|------------|
| SixPar 200 | |
| <p>The indoor version SIXPAR 200™ features (12) 12W 6-IN-1 RGBAW+UV LEDs, 15° beam and 25° field angles, electronic strobe and dimming (0-100%), 5 variable dimming curve modes, dual yoke / floor stand, multiple unit power linking, RDM (remote device management), rugged die-cast aluminum exterior, flicker free operation for TV and FILM, and a multi-voltage universal auto switching power supply (110-250v).</p> | |
| ELA0324 | SixPar 200 |

| | |
|---|--------------|
| SixPar 200IP | |
| <p>The new IP65 rated SIXPAR 200IP™ features (12) 12W 6-IN-1 RGBAW+UV LEDs, 15° beam and 25° field angles, electronic strobe and dimming (0-100%), 5 variable dimming curve modes, dual yoke / floor stand, multiple unit power linking, RDM (remote device management), rugged die-cast aluminum exterior, flicker free operation for TV and FILM, 150W max power consumption, and a multi-voltage universal auto switching power supply (110-250v).</p> | |
| ELA0325 | SixPar 200IP |

| | |
|---|---------------|
| SixPar 200WMG | |
| <p>The IP65 outdoor rated SIXPAR 200WMG includes the same features as the standard SIXPAR 200IP model but with a special added White Marine Grade exterior coating designed for the marine/coastal environment installations.</p> | |
| ELA0326 | SixPar 200WMG |

| | |
|--|------------------|
| SixPar 200WMG HW | |
| <p>The IP65 outdoor rated SIXPAR 200WMG HW includes the same features as the standard SIXPAR 200IP model but a special added White Marine Grade exterior coating and Hard Wired (bare wire) IP-rated power/data combo in/out cables attached, designed for permanent marine/coastal environment installations.</p> | |
| ELA0327 | SixPar 200WMG HW |

| | |
|---|------------|
| SixPar 300 | |
| <p>The indoor version SIXPAR 300™ features (18) 12W 6-IN-1 RGBAW+UV LEDs, 15° beam and 25° field angles, electronic strobe and dimming (0-100%), 5 variable dimming curve modes, dual yoke / floor stand, multiple unit power linking, RDM (remote device management), rugged die-cast aluminum exterior, flicker free operation for TV and FILM, and a multi-voltage universal auto switching power supply (110-250v).</p> | |
| ELA0328 | SixPar 300 |

| | |
|--|---------------|
| SixPar 300WMG | |
| <p>The IP65 outdoor rated SIXPAR 300WMG includes the same features as the standard SIXPAR 300IP model but with a special added White Marine Grade exterior coating designed for marine/coastal environment installations.</p> | |
| <p>Featuring (18) 12W 6-in-1 RGBAW+UV LEDs producing a 23° beam angle, internal color and color chase macros, electronic strobe and variable dimming curve modes, manual and DMX-512 control, RDM (remote device management) support, dual yoke / floor stand, multiple unit power linking, rugged die-cast aluminum white marine grade coated exterior, flicker free operation for TV and FILM, and a multi-voltage universal auto switching power supply (110-250v).</p> | |
| ELA0330 | SixPar 300WMG |

| | |
|---|------------------|
| SixPar 300WMG HW | |
| <p>The IP65 outdoor rated SIXPAR 300WMG HW includes the same features as the standard SIXPAR 300IP model but with a special added White Marine Grade exterior coating and Hard Wired (bare wire) IP-rated power/data combo in/out cables attached, designed for permanent marine/coastal environment installations.</p> | |
| ELA0331 | SixPar 300WMG HW |



SixBar

SixBar 500

The SIXBAR 500™ features (6) 12W 6-IN-1 RGBAW+UV LEDs, 100,000 average hour LED life, 30° beam angle, individual control of each LED, variable dimming curve modes, strobe and chase effects, a UV wavelength of 395nm, ArtNet, KlingNet and RDM (remote device management) protocol support, 3pin and 5pin DMX, Locking Power Cable and RJ45 in/out connections, LCD menu display with 4 button control panel, integrated dual rigging brackets, multiple unit power linking, rugged die-cast aluminum exterior, frost filter and glare shield included, flicker free operation for TV and FILM, 93W max power consumption, and a multi-voltage universal auto switching power supply (110-240v).



ELA0321 SixBar 500

SixBar 1000

The SIXBAR 1000™ features (12) 12W 6-IN-1 RGBAW+UV LEDs, 100,000 average hour LED life, 30° beam angle, individual control of each LED, variable dimming curve modes, strobe and chase effects, a UV wavelength of 395nm, ArtNet, KlingNet and RDM (remote device management) protocol support, 3pin and 5pin DMX, Locking Power Cable, and RJ45 in/out connections, LCD menu display with 4 button control panel, integrated dual rigging brackets, multiple unit power linking, rugged die-cast aluminum exterior, frost filter and glare shield included, flicker free operation for TV and FILM, 145W max power consumption, and a multi-voltage universal auto switching power supply (110-240v).



ELA0319 SixBar 1000

SixBar 1000 IP

The IP65 rated SIXBAR 1000 IP™ features (12) 12W 6-IN-1 RGBAW+UV LEDs, 25° beam angle, pixel control, variable dimming curve modes, strobe and chase effects, a UV wavelength of 395nm, RDM (remote device management) protocol support, IP rated DMX and power in/out connections, LCD menu display with 4 touch button control panel, dual adjustable rigging/floor stand brackets, glare shield and frost filter included, multiple unit power linking, rugged die-cast aluminum exterior, flicker free operation for TV and FILM, 145W max power consumption, and a multi-voltage universal auto switching power supply (110-240v).



ELA0320 SIXBAR 1000IP

Limelight

Limelight Par L

The LIMELIGHT PAR L engine features (12) 60W RGBL LED's, capable of producing 8,213 lumens, provides high output for saturated color mixing, and the wide color spectrum and high CRI needed for the quality of light that key and fill light applications require. The newly designed optical system allows for a highly homogenized output with even color and light distribution throughout the beam. The fixture also features a wide zoom range from 5° to 40°. The smooth and responsive effect provides a well-defined narrow beam for mid-air effects and long throw distances as well as a wide and even wash coverage at shorter distances.



ELA0172 Limelight Par L

Limelight Par S

The LIMELIGHT PAR S engine features (7) 60W RGBL LED's, capable of producing 5,345 lumens, provides high output for saturated color mixing, and the wide color spectrum and high CRI needed for the quality of light that key and fill light applications require. The newly designed optical system allows for a highly homogenized output with even color and light distribution throughout the beam. The fixture also features a wide zoom range from 5° to 42°. The smooth and responsive effect provides a well-defined narrow beam for mid-air effects and long throw distances as well as a wide and even wash coverage at shorter distances.



ELA0173 Limelight Par S

Pixel

Pixel Wash 40IP

The PIXEL WASH 40IP is a lightweight, outdoor IP65 rated LED wash / effect par fixture featuring 4 in 1, 10-watt RGBW LED's, a PWM (pulse width modulation) of 44,000Hz for flicker free operation for broadcast, TV, and film applications, a beam angle of 32° and a field angle of 60°. This unit features two integrated 4pin power/data in and out whips with locking connectors.



ELA0232 Pixel Wash 40IP

Pixel Bar 30IP

The PIXEL BAR 30IP™ is an outdoor IP65 rated LED pixel bar featuring (30) tri-color RGB SMD LEDs with a 16mm pixel pitch, a refresh rate of 44,000Hz for flicker free operation for broadcast TV and FILM applications, and measures 0.5 meter (1.6 feet) in length. Each pixel bar is housed in a lightweight IP65 rated aluminum housing featuring magnetic end caps which allow seamless end-to-end pixel spacing, an integrated adjustable mounting bracket, a safety cable loop, and includes square and rounded frosted lens attachments.



ELA0225 Pixel Bar 30 IP



Pixel Bar 60IP

The PIXEL BAR 60IP™ is an outdoor IP65 rated LED pixel bar featuring (60) tri-color RGB SMD LEDs with a 16mm pixel pitch, a refresh rate of 44,000Hz for flicker free operation for broadcast TV and FILM applications, and measures 1 meter (3.3 feet) in length. Each pixel bar is housed in a lightweight IP65 rated aluminum housing featuring magnetic end caps which allow seamless end-to-end pixel spacing, an integrated adjustable mounting bracket, a safety cable loop, and includes square and rounded frosted lens attachments.



ELA0226 Pixel Bar 60 IP

Pixel BFMCC

This is a Female Chassis mount connector for the Pixel Bar IP Series power/data cable.



ELA0227 PIXEL BFMCC

Pixel BMCC

This is a Male Chassis mount connector for the Pixel Bar IP Series power/data cable.



ELA0228 PIXEL BMCC

Pixel Bar 120IP

The PIXEL BAR 120IP™ is an outdoor IP65 rated LED pixel bar featuring (120) tri-color RGB SMD LEDs with a 16mm pixel pitch, a refresh rate of 44,000Hz for flicker free operation for broadcast TV and FILM applications, and measures 2 meter (6.6 feet) in length. Each pixel bar is housed in a lightweight IP65 rated aluminum housing featuring magnetic end caps which allow seamless end-to-end pixel spacing, an integrated adjustable mounting bracket, a safety cable loop, and includes square and rounded frosted lens attachments.



ELA0224 Pixel Bar 120 IP

Pixel Amp 200

The Pixel Amp 200 is a 200W power and signal amplifier for the Pixel Wash 40IP. This amplifier is designed to work in conjunction with the Elation Pixel Driver 170IP, Pixel Driver 1000IP or the Pixel Driver 4000V3. Each Pixel Amp 200 can power up to 8 Pixel Wash 40IP's in standard mode or 5 Pixel Wash 40IP's in HiPower mode. Up to 4 Pixel Amp 200's can be used in line for each driver output giving you the ability to control a total of 40 Pixel Wash 40IP's in standard mode or 25 Pixel Wash 40IP's in HiPower mode for each driver output. The unit comes equipped with Power In, Data In/Out pigtail connections, and is IP65 rated, which protects the unit from the ingress of dust, as well as low pressure water jets sprayed from any direction.



ELA0217 Pixel Amp 200

Drivers

Pixel Driver 4000 V3

PIXEL DRIVER 4000 V3™ is designed specifically for the Elation PIXEL TAPE 16IP, 40IP, PIXEL BAR 30IP, 60IP, 120IP series and PIXEL WASH 40IP, and provides easy and versatile control options including simple on-board manual dimming and strobe control, and full pixel mapping control of 4,080 max pixels, 1,020 pixels per port, via Kling-Net, Art-Net and sACN (streaming ACN) protocols.



ELA0231 Pixel Driver 4000 V3

Pixel Driver 1000IP

PIXEL DRIVER 1000IP™ is designed specifically for the Elation PIXEL BAR 30IP, 60IP, and 120IP series, and provides easy and versatile control options including simple on-board manual dimming and strobe control, and full pixel mapping control of 1,020 max pixels via ArtNet, sACN or Kling-Net protocols.



ELA0229 Pixel Driver 1000IP

Pixel Driver 170IP

PIXEL DRIVER 170IP™ is a professional, IP65, driver specifically designed for the Elation PIXEL TAPE 16IP, PIXEL TAPE 40IP and PIXEL WASH 40IP. This driver provides simple and easy control options including a 4-button OLED Display, EL IR Remote (included), and one full universe of DMX control (170 pixels). The PIXEL DRIVER 170IP features an easy-to-use OLED display, Pixel grouping, DMX IN and OUT, a 4pin XLR connector for LED output, and a 2pin connector for 12-24VDC power IN.



ELA0230 Pixel Driver 170IP



Pixel Lenses

Pixel B120RFL

This is a replacement Rounded Frost lens to fit the Pixel Bar 120IP Fixture

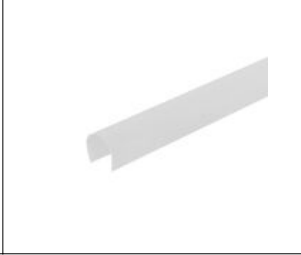

ELA0218 PIXEL B120RFL

Pixel B120SFL

This is a replacement Square Frost lens to fit the Pixel Bar 120IP Fixture

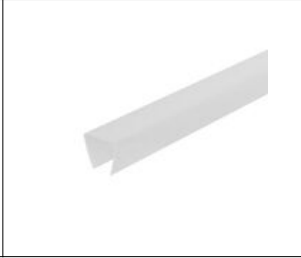

ELA0219 PIXEL B120SFL

Pixel B30RFL

This is a replacement Round Frost lens to fit the Pixel Bar 30IP Fixture

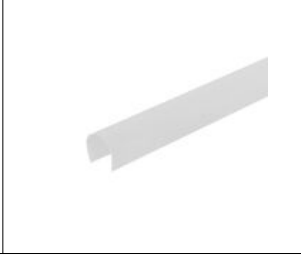

ELA0220 PIXEL B30RFL

Pixel B30SFL

This is a replacement Square Frost lens to fit the Pixel Bar 30IP Fixture

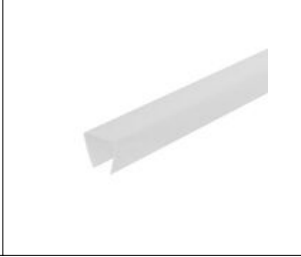

ELA0221 PIXEL B30SFL

Pixel B60RFL

This is a replacement Rounded Frost lens to fit the Pixel Bar 60IP Fixture

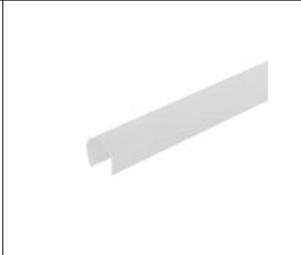

ELA0222 PIXEL B60RFL

Pixel B60SFL

This is a replacement Square Frost lens to fit the Pixel Bar 60IP Fixture

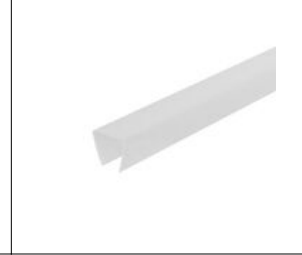

ELA0223 PIXEL B60SFL

Magmatic

MagRemote VIDI

MagRemote VIDI is compatible with Magmatic's line of products, like the Therma series, Magma series, and Polar series. "Rocket Series is not fully compatible with the remote"



ELA0184 MagRemote VIDI

Sidewinder

The MAGMATIC SIDEWINDER is a high-velocity CO2 simulator fog machine, including 22 x 3-watt RGBA LEDs (Red X5 Green X6 Blue X6 Amber X5). The Sidewinder can burst fog in multiple positions, rotating 180° degrees. Equipped with an easy to use onboard LCD touch screen control panel, intuitive DMX-512, RDM control, durable aluminum housing, and optional wired and wireless remote control options.



ELA0304 SIDEWINDER

Javelin

A member of MAGMATIC'S Rocket series of CO2 cryogenic simulation effects, the MAGMATIC JAVELIN™ is a high-velocity CO2 simulator fog machine for high-impact moments. Featuring 34 x 3-watt RGBA (Red X10 Green X8 Blue X8 Amber X8) LEDs for throws of dynamic colored effect, the JAVELIN can rotate 90-degrees for horizontal or vertical bursts of fog. Wrapped in a durable aluminum housing, the JAVELIN is intuitively controllable via DMX-512 and RDM and houses an easy-to-use onboard LCD touch screen control panel. Wired and wireless remote control options are available.



ELA0131 JAVELIN



Magma Prime

MAGMA PRIME™ is a water-based fazer with advanced technology providing a high-volume dry faze effect with low fluid consumption. The new HPA (high pressure air) pump technology reduces the risk of heater clogging. Features includes an easy to use onboard LCD touch screen control panel, intuitive DMX-512 and RDM control, a durable aluminum housing, and optional wired and wireless remote control options.



ELA0183 | MAGMA PRIME

Therma Tour 600

The THERMA TOUR 600 is a premium haze effect generator that produces an exceptionally fine, long-lasting atmospheric haze that excels at revealing light beams and mid-air effects. The 350W THERMA TOUR 600 creates a safe, clean and odorless haze effect that leaves no residue.



ELA0406 | THERMA TOUR 600

MAGFLY

MAGFLY is a wireless DMX receiver card compatible with all Magmatic foggers, hazers, snow machines, CO2 simulators, low-lying, and bubble machines. Compatible with MAGMATIC MAGFLY and Elation Efly transceivers.



ELA0180 | MAGFLY

Magma Prime FC

The Magma Prime FC is a rugged road case, custom-built to protect and conveniently operate the Magmatic Magma Prime. Ideal for mobile entertainers and production crews, it ensures your valuable effects equipment stays safe during transport.



Therma Tour 800

The Therma Tour 800 is a powerful oil-based haze effect generator that produces an exceptionally fine, long-lasting atmospheric haze that excels at revealing light beams and mid-air effects. The 800W THERMA TOUR 800 creates a safe, clean and odorless haze effect that leaves no residue.



ELA0407 | THERMA TOUR 800

Crisp

CRISP™ is a high volume compact lightweight snow machine with advanced technology providing adjustable snowflake size, along with a lower operating noise for noise-sensitive environments. The new the Auto-Clean feature, provides less clogging and requires less maintenance. Features include an easy-to-use onboard LCD touch screen control panel, intuitive DMX-512, and RDM control, durable aluminum housing, and optional wired and wireless remote control options.



ELA0058 | CRISP

Crisp Max

POLAR CRISP MAX™ from MAGMATIC atmospheric effects, a dependable, high-output snow machine that makes it easy to create scene-setting wintry settings. CRISP MAX is capable of producing high volumes of naturalistic snow with the capacity to adjust snowflake size for greater versatility. It includes a 20-liter fluid tank hidden inside a road case with durable casters for easier portability. The unit's 10-meter long hose can be rigged on a standard truss or tripod stand and can extend up to 30 meters horizontally or vertically.



ELA0059 | CRISP MAX

PM-DMX1

MAGMATIC PM-DMX1™ is an optional pan motor accessory for the MAGMATIC CRISP MAX™ Snow Machine. Install the output nozzle of the Crisp Max, using the included mounting bracket, onto the PM-DMX1 to precisely control 120 degrees of pan movement via DMX-512 or manually using the 4-button LED control panel menu display on the unit.



ELA0233 | PM-DMX1

Magma Fog 1500 IP-II

The MAGMA FOG 1500 IP-II™ is a 1500W water based, IP67 rated fog machine with a maximum output of 60,000 CFM (cu ft/min). Features include an easy-to-use onboard LCD touch screen, an intuitive DMX-512 and RDM control, and optional wired and wireless remote-control. Each MAGMA FOG 1500 IP-II comes equipped with a thermally protected heat exchanger that has an initial warm up time of 14 minutes, with a fluid consumption rate of 6.76 oz (200 ml/min). This unit is designed with a durable aluminum housing, IP65 locking power in, IP65 locking 5pin XLR connectors (DMX In/Out), a 5-liter (1.32 gallon) tank, two heavy duty carry handles, and a hanging bracket for truss mounting.



ELA0182 | MAGMA FOG 1500 IP-II



MagRF

The MAGMATIC MAGRF™ is a 433-MHz wireless remote control that is compatible with all MAGMATIC foggers, hazers, snow machines, CO2 simulators, low lying, and bubble machines. Once the receiver unit is installed, it has an effective range of up to 150-feet with clear line-of-sight (50-meters) to manually control the output of your Magmatic machine.



ELA0185 | MagRF

MagRF-R

The MAGMATIC MAGRF-R™ is a 433 MHz wireless receiving card with a working distance of 150 feet. This wireless receiving card works in conjunction with the MAGRF-T™ and is compatible with all MAGMATIC foggers, hazers, snow machines, CO2 simulators, low lying machines, and bubble machines.



ELA0186 | MagRF-R

MagRF-T

The MAGMATIC MAGRF-T™ is a 433 MHz wireless transmitting remote with a working distance of 150 feet. This wireless transmitter works in conjunction with the MAGRF-R™ (receiver) and is compatible with all MAGMATIC foggers, hazers, snow machines, CO2 simulators, low lying machines, and bubble machines.



ELA0187 | MagRF-T

MAGMAFAN 1

MAGMAFAN 1 is a compact all-purpose stage fan that features multiple control options, linear output control, low power consumption, adjustable blowing directions, and durable metal housing. Low power consumption is only 80W, allowing you to put on the same circuit as your fog machine. The adjustable mounting/floor bracket included enables you to adjust the fan output 90 degrees. Easy to use onboard LCD touch screen control panel, intuitive DMX-512, and RDM control. Its durable aluminum housing design allows easy carry and storage, with optional wired and wireless remote control.



ELA0181 | MAGMA FAN 1

PSCM Hose-10M

This is a 10 metre extension hose assembly (for both power & fluid delivery) for the Crisp Max. It allows the snow cannon unit to deploy further away from the main Crisp Max unit. A maximum of 3 hoses can be joined to extend a total of 30 metres from the main unit. It connects easily in seconds, with no special tools needed. Note - The Crisp Max already ships with one of these 10 metre extension hoses inside the storage hatch.



ELA0290 | PSCM Hose-10M

Prisma

Prisma Par 50

PRISMA PAR 50™ is an exterior IP65 rated UV wash par luminaire that produces 365nm peak true UV output with zero visible light, and an impressive 50 degree wide beam angle from the large internal LED reflector. Features includes a user friendly digital 2.5 inch LCD touch screen control panel, intuitive DMX-512 and RDM control, dual adjustable mounting yokes, a durable aluminum housing, and IP65 DMX 5pin XLR and locking power in/out connections.



ELA0241 | Prisma Par 50

Prisma Par 20

PRISMA PAR 20™ is an exterior IP65 rated UV wash par luminaire that produces 365nm peak true UV output with zero visible light. Features include a 20 degree narrow beam angle, a user friendly digital 2.5 inch LCD touch screen control panel, intuitive DMX-512 and RDM control, dual adjustable mounting yokes, a durable aluminum housing, IP65 DMX 5pin XLR and locking power in/out connections.



ELA0240 | Prisma Par 20

Prisma Wash 100

PRISMA WASH 100™ is an exterior IP65 rated UV wash luminaire that produces 365nm peak true UV output with zero visible light. Features include a scoop LED reflector design which creates an impressive 90 degree wide beam angle, manual adjustable tilt positioning and versatile rigging options, a user friendly digital 2.5 inch LCD touch screen control panel, intuitive DMX-512 and RDM control, and IP rated power and data in/out.



ELA0243 | Prisma Wash 100

Prisma Wash 25

PRISMA WASH 25™ is an exterior IP65 rated UV wash luminaire that produces 365nm peak true UV output with zero visible light. Features include an impressive 20 degree narrow beam angle, manual adjustable tilt positioning and versatile rigging options, a user friendly digital 2.5 inch LCD touch screen control panel, intuitive DMX-512 and RDM control.



ELA0244 | Prisma Wash 25

Prisma Mini Par 45

PRISMA MINI PAR 45™ is an IP65-rated exterior UV wash par luminaire that produces 365nm peak true UV output with zero visible light, and an impressive 45-degree beam angle.

Powered by the PRISMA DRIVER 8™ or PRISMA DRIVER 8IP™, 'Not Included'



ELA0238 | Prisma Mini Par 45



Prisma Mini Par 20

PRISMA MINI PAR 20™ is an IP65-rated exterior UV wash par luminaire that produces 365nm peak true UV output with zero visible light, and an impressive 20-degree beam angle.

Powered by the PRISMA DRIVER 8™ or PRISMA DRIVER 8IP™, 'Not Included'



ELA0237 Prisma Mini Par 20

Prisma Mini Bar Black Glass

Black glass filters are available for all Prisma™ series UV LED lighting products. The black glass filter blocks all visible light, allowing only the ultraviolet spectrum to effectively illuminate the UV reactive material and nothing else. By completely blacking out all visible light, the black glass filters allow Prisma fixtures to hide discreetly in themed environments, clubs, glow events, or productions of all types.



ELA0236 Prisma Mini Bar Black Glass

Prisma Mini Bar 20

PRISMA MINI BAR 20™ is an IP65 rated exterior UV wash bar luminaire that produces 365nm peak true UV output with zero visible light, and an impressive 20 degree beam angle.

Powered by the PRISMA DRIVER 8™ or PRISMA DRIVER 8IP™ 'Not Included'



ELA0235 Prisma Mini Bar 20

Prisma Par Black Glass

Black glass filters are available for all Prisma™ series UV LED lighting products. The black glass filter blocks all visible light, allowing only the ultraviolet spectrum to effectively illuminate the UV reactive material and nothing else. By completely blacking out all visible light, the black glass filters allow Prisma fixtures to hide discreetly in themed environments, clubs, glow events, or productions of all types.



ELA0242 Prisma Par Black Glass

Prisma Drivers

Prisma Driver 8

PRISMA DRIVER 8™ is an easy to use 48VDC driver system which provides individual DMX-512 control including variable delayed time dimming modes for up to (8) PRISMA MINI UV LED series fixtures including the PRISMA MINI PAR 20™, PRISMA MINI PAR 45™, and the PRISMA MINI BAR 20™.



ELA0234 Prisma Driver 8

Prisma Mini Par Black Glass

Black glass filters are available for all Prisma™ series UV LED lighting products. The black glass filter blocks all visible light, allowing only the ultraviolet spectrum to effectively illuminate the UV reactive material and nothing else. By completely blacking out all visible light, the black glass filters allow Prisma fixtures to hide discreetly in themed environments, clubs, glow events, or productions of all types.



ELA0239 Prisma Mini Par Black Glass

Aria X2

Aria X2 Bridge

The single universe, indoor Aria X2 Bridge, the future of wireless lighting management, is here to transform your experience with unparalleled control, efficiency and ease. This comprehensive system harnesses cutting-edge technology to offer you a solution that adapts to your needs and provides a harmonious lighting experience, whether on show site or in the shop. In addition to transmitting the Aria X2 serial protocol, Aria X2 Bridge is also compatible with ADJ WiFLY, Elation eFly, Magmatic MagFly and Acclaim Aria.



ELA0025 Aria X2 Bridge

Black Glass Accessories

Prisma Wash Black Glass

Black glass filters are available for all Prisma™ series UV LED lighting products. The black glass filter blocks all visible light, allowing only the ultraviolet spectrum to effectively illuminate the UV reactive material and nothing else. By completely blacking out all visible light, the black glass filters allow Prisma fixtures to hide discreetly in themed environments, clubs, glow events, or productions of all types.



ELA0245 Prisma Wash Black Glass



Aria X2 IPC

The versatile Aria X2 IPC wireless DMX / fixture management controller. Featuring a single DMX universe, this device operates seamlessly with 900MHz, 2.4 GHz WiFi, and Bluetooth connectivity. Its IP65 housing ensures durability, making it suitable for both indoor and outdoor applications. With support for various protocols including DMX, Bluetooth 5.2, and our proprietary Aria X2 Mesh Protocol, this controller offers flexibility and ease of use. Complete with front panel configuration and future app compatibility, it's the perfect solution for lighting professionals.



ELA0026 | Aria X2 IPC

Aria X2 IPC Bridge

The single universe, IP65 rated Aria X2 Bridge, the future of wireless lighting management, is here to transform your experience with unparalleled control, efficiency and ease. This comprehensive system harnesses cutting-edge technology to offer you a solution that adapts to your needs and provides a harmonious lighting experience, whether on show site or in the shop. In addition to transmitting the Aria X2 serial protocol, Aria X2 Bridge is also compatible with ADJ WiFLY, Elation eFly, Magmatic MagFly and Acclaim Aria.



ELA0027 | Aria X2 IPC Bridge

Aria X2 Shelf

19" Rackmount Shelf - the ultimate solution for organizing and securing your Aria X2 Transceiver and Aria X2 Bridge devices.



ELA0028 | Aria X2 Shelf

Aria X2 Transceiver

The single universe, indoor Aria X2 Transceiver, the future of wireless lighting management, is here to transform your experience with unparalleled control, efficiency and ease. This comprehensive system harnesses cutting-edge technology to offer you a solution that adapts to your needs and provides a harmonious lighting experience, whether on show site or in the shop.



ELA0029 | Aria X2 Transceiver

Capture

Capture 2024 Duet

Obsidian Control Systems distributed exclusively by Elation has partnered with Capture to offer a FREE upgradable Capture 2024 Duet key with the NX4 lighting controller or a Solo key with the NX2 lighting controller. Software cannot be returned. Product names used on this page may be trademarks or registered trademarks of their respective companies and are hereby acknowledged.



ELA0039 | CAPTURE 2024 DUET

Capture 2024 Duet Quartet Upgrade



ELA0040 | CAPTURE 2024 DUET QUARTET UPGRADE

Capture 2024 Duet Symphony Upgrade



ELA0041 | CAPTURE 2024 DUET SYMPHONY UPGRADE

Capture 2024 Quartet

Obsidian Control Systems distributed exclusively by Elation has partnered with Capture to offer a FREE upgradable Capture 2024 Duet key with the NX4 lighting controller or a Solo key with the NX2 lighting controller.

Software cannot be returned. Product names used on this page may be trademarks or registered trademarks of their respective companies and are hereby acknowledged.



ELA0042 | CAPTURE 2024 QUARTET

Capture 2024 Quartet Symphony Upgrade

Updating your Capture license to the latest Capture gives you loads of new features to use for your future drawings and virtual programming.



ELA0043 | CAPTURE 2024 QUARTET SYMPHONY UPGRADE



Capture 2024 Solo

Obsidian Control Systems distributed exclusively by Elation has partnered with Capture to offer a FREE upgradable Capture 2024 Duet key with the NX4 lighting controller or a Solo key with the NX2 lighting controller. Software cannot be returned. Product names used on this page may be trademarks or registered trademarks of their respective companies and are hereby acknowledged.



ELA0044 CAPTURE 2024 SOLO

Duet to 2024 Duet

Updating your Capture license to the latest Capture gives you loads of new features to use for your future drawings and virtual programming.



ELA0075 DUET TO 2024 DUET

Capture 2024 Solo Duet Upgrade

Updating your Capture license to the latest Capture gives you loads of new features to use for your future drawings and virtual programming.



ELA0045 CAPTURE 2024 SOLO DUET UPGRADE

Quartet to 2024 Quartet

Updating your Capture license to the latest Capture gives you loads of new features to use for your future drawings and virtual programming.



ELA0295 QUARTET TO 2024 QUARTET

Capture 2024 Solo Quartet Upgrade

Updating your Capture license to the latest Capture gives you loads of new features to use for your future drawings and virtual programming.



ELA0046 CAPTURE 2024 SOLO QUARTET UPGRADE

Solo to 2024 Solo

Updating your Capture license to the latest Capture gives you loads of new features to use for your future drawings and virtual programming.



ELA0404 SOLO TO 2024 SOLO

Capture 2024 Solo Symphony Upgrade

Updating your Capture license to the latest Capture gives you loads of new features to use for your future drawings and virtual programming.



ELA0047 CAPTURE 2024 SOLO SYMPHONY UPGRADE

Symphony to 2024 Symphony

Updating your Capture license to the latest Capture gives you loads of new features to use for your future drawings and virtual programming.



ELA0405 SYMPHONY TO 2024 SYMPHONY

Capture 2024 Symphony

Obsidian Control Systems distributed exclusively by Elation has partnered with Capture to offer a FREE upgradable Capture 2024 Duet key with the NX4 lighting controller or a Solo key with the NX2 lighting controller. Software cannot be returned. Product names used on this page may be trademarks or registered trademarks of their respective companies and are hereby acknowledged.



ELA0048 CAPTURE 2024 SYMPHONY



Accessories

A-Loader HH

The A loader HH™ is a battery powered hand held software uploader device used to update Elation compatible lighting fixtures. Easily upload a software update to an Elation lighting fixture by connecting the uploader to the fixture using a 3pin or 5pin DMX cable (not included). Elation software updates (not included) are stored on a SD card (included) and inserted into the uploader. A loader HH™ features an LCD display, 4 push button control panel, a SD card slot, 3pin and 5pin XLR DMX outputs, an On/Off switch and includes a 12VDC external power supply and blank SD card.



ELA0005 | A-Loader HH

C-Loader II

The C loader-II™ is a battery powered hand held software uploader device used to update and test Elation compatible lighting fixtures. Easily upload a software update to an Elation lighting fixture by connecting the uploader to the fixture using a 3pin DMX cable (not included). Elation software updates (not included) are stored on a MICRO SD card (included) and inserted into the uploader. The C-Loader-II™ can also be used as a DMX and RDM Tester. The C loader-II™ features an LCD display, 6 button control panel, a MICRO SD card slot, a 3pin XLR DMX output, an On/Off switch, and includes battery, USB cable, USB to MICRO SD card adapter and blank MICRO SD card.



ELA0038 | C-Loader II

E-Fly Transceiver

The E-FLY™ Transceiver is a long range wireless DMX Transceiver (Transmitter/Receiver in one) that is compatible with other E-FLY™ products and includes a rechargeable battery, which provides a solution for remote applications where access to power is a challenge. Connected to a DMX Controller, the E-FLY™ Transceiver will provide a constant and reliable wireless DMX signal up to 2,500 feet (762m) to other Elation E-FLY™ products. The 2.4 GHz wireless frequency will coexist in busy RF environments alongside technologies like Bluetooth and Wi-Fi.



ELA0081 | E-Fly Transceiver

E-Loader III Softw.Update Box f. Elation

The E-LOADER III™ is a battery powered hand held software uploader device used to update Elation compatible lighting fixtures. Easily upload a software update to an Elation lighting fixture by connecting the E-LOADER III™ to the fixture using the included 3pin DMX cable. Elation software updates (not included) are stored on a MICRO SD card (included) and inserted into the uploader. E-LOADER III™ features an LCD display, 6 button control panel, a MICRO SD card slot, a 3pin XLR DMX output, an On/Off switch, and includes battery, 3pin DMX cable, USB cable, USB AC adapter, USB to MICRO SD card adapter, and a blank MICRO SD card.



ELA0082 | E-Loader III Softw.Update Box f. Elation

KL Spot IP Framing Module

This optional module can be installed to add fully automated blackout framing shutters to the KL Spot IP.
4 Fully Automated Full Blackout Framing Blades, +/- 60 Indexing



ELA0166 | KL SPOT IP Framing Module

SL Bowens Adapter (SOL BA)



ELA0389 | S?L Bowens Adapter (SOL BA)

SL Gel Frame Holder Kit (SOL GFHK)



ELA0392 | S?L Gel Frame Holder Kit (SOL GFHK)

SL I Heavy Duty Yoke (SOL1 Y)



ELA0395 | S?L I Heavy Duty Yoke (SOL1 Y)

SL I Rear Mount Bracket (SOL1 RMB)



ELA0399 | S?L I Rear Mount Bracket (SOL1 RMB)



WP-06

If it's an installation or an event, whenever it's outdoors, there's a chance of rain. To make sure the gear is protected, outdoor domes come into use. When extra protection regarding heat and humidity is needed, the WP-06 is the right tool for the job.



ELA0421

WP-06

MULTI-DATA/PAK - Demultiplexer

Converts DMX into analog signals
Converts MIDI Data to analog signals



ELA0188

MULTI-DATA/PAK - Demultiplexer

EZ Kling

The EZ KLING™ is an RJ45 to DMX, KlingNet™, ArtNet and sACN interface, which allows you to pixel map KlingNet™ and DMX compatible fixtures through the KlingNet™ mapper included in Media Master Express™ and Media Master Pro™ (not included). Ideal for use with Flex Pixel Tape™ and LED Pixel controllable DMX fixtures. One EZ KLING™ interface will drive up to 600 Flex Pixel RGB pixels using KlingNet™ control protocol or 170 DMX Pixels via ArtNet/ DMX control. EZ Kling™ can also be used as a 1-port Node to convert ArtNet to DMX. Includes a magnet on the back panel for easy metal surface mounting and a mini omega bracket for clamp/truss mounting.



ELA0084

EZ Kling

IP Tester

The IP TESTER is a unique mobile service tool developed by Elation to test the integrity of any compatible IP-rated lighting fixture such as Elation's PROTEUS series fixtures, after being opened for lamp and gobo replacement or repair. Unlike other IP fixture test devices currently available in the market, Elation's IP TESTER has been designed to test for both Vacuum and Pressure leaks.



ELA0129

IP Tester

IPC415

The IPC415™ is a 19" rack mountable intelligent DMX power control center, featuring 4 locking power outputs (15A each), 4 5pin XLR DMX outputs, 1 5pin XLR DMX input and 1 5pin XLR DMX through and a multi-voltage universal auto switching power supply (100-240v 50/60Hz). Power to the power outputs can be scheduled to automatically switch On/Off via an internal scheduler when DMX signal is lost or when a specific cue is triggered from a DMX console. The IPC415™ can be mounted with the 19" rackmounts or truss mounted using a clamp (not included) attached to the M10 rigging point in the center of the unit.



ELA0130

IPC415

LTrack C-Clamp 44.5mm (CA2)

The 44.5mm L-Track Narrow Clamp adapter is specifically designed for seamless integration with the Pulse Bar S, Pulse Bar L, Pulse Panel, Six+ Bar S and Six+ Bar L. Offering unmatched versatility and reliability, it secures your valuable equipment with precision. This adapter, crafted with meticulous engineering, guarantees a perfect fit within the Pulse Bar S, Pulse Bar L, and Pulse Panel ecosystem, providing a hassle-free solution for mounting and securing your gear.



ELA0174

LTrack C-Clamp 44.5mm (CA2)

Interconnect Clamp Adapter

Interconnect Clamp Adapter



LTrack C-Clamp 70mm (CA1)

The 70.1mm L-Track Narrow Clamp adapter is specifically designed for seamless integration with the Pulse Bar S, Pulse Bar L, Pulse Panel, Six+ Bar S and Six+ Bar L. Offering unmatched versatility and reliability, it secures your valuable equipment with precision. This adapter, crafted with meticulous engineering, guarantees a perfect fit within the Pulse Bar S, Pulse Bar L, Pulse Panel, Six+ Bar S and Six+ Bar L ecosystem, providing a hassle-free solution for mounting and securing your gear.



ELA0175

LTrack C-Clamp 70mm (CA1)



LTrack to M10 Adapter, 44.5mm (A2)

The 44.5mm L-Track clamp adapter is specifically designed for seamless integration with the Pulse Bar S, Pulse Bar L, Pulse Panel, Six+ Bar S and Six+ Bar L. Offering unmatched versatility and reliability, it secures your valuable equipment with precision. This adapter, crafted with meticulous engineering, guarantees a perfect fit within the Pulse Bar S, Pulse Bar L, Pulse Panel, Six+ Bar S and Six+ Bar L ecosystem, providing a hassle-free solution for mounting and securing your gear.



ELA0176 LTrack to M10 Adapter, 44.5mm (A2)

LTrack to M10 Adapter,70mm (A1)

The 70.1mm L-Track clamp adapter is specifically designed for seamless integration with the Pulse Bar S, Pulse Bar L, Pulse Panel, Six+ Bar S and Six+ Bar L. Offering unmatched versatility and reliability, it secures your valuable equipment with precision. This adapter, crafted with meticulous engineering, guarantees a perfect fit within the Pulse Bar S, Pulse Bar L, Pulse Panel, Six+ Bar S and Six+ Bar L ecosystem, providing a hassle-free solution for mounting and securing your gear.



ELA0177 LTrack to M10 Adapter,70mm (A1)

Barndoor for LIMELIGHT PAR L

The LIMELIGHT PAR L Barndoor offers precise control over light direction and spill. Crafted with durable materials and a sleek black finish, it effortlessly attaches to the LIMELIGHT PAR L, allowing you to shape and direct light with ease. Its 8-leaf design provides precise control over the beam of light, enabling creative manipulation of shadows and highlights. This makes the LIMELIGHT PAR L Barndoor an essential tool for controlling and shaping light to perfection.



ELA0034 Barndoor for LIMELIGHT PAR L

Barndoor for Paladin Brick

This barndoor assembly installs in seconds onto your Paladin Brick unit, giving you further control of the light distribution.



ELA0035 Barndoor for Paladin Brick

Barndoor for Paladin Cube

This barndoor assembly installs in seconds onto your Paladin Cube unit, giving you further control of the light distribution.



ELA0036 Barndoor for Paladin Cube

Barndoor for Paladin Panel

This barndoor assembly installs in seconds onto your Paladin Panel unit, giving you further control of the light distribution.



ELA0037 Barndoor for Paladin Panel

FW500 Motorized Barndoors

The FUZE WASH 500 Motorized Barndoors enhance the fresnel optic with a fully remote-controlled external beam shaping system. The result are smooth defined edges for excellent area control in any application. The barndoors are flocked to reduce reflections and feature intelligent collision avoidance detection. They can fully close for transportation and lens protection and the entire assembly can index +/- 60°. The barndoors are easy to install onto the front of the fixture with four screws and a simple cable connection. The DMX layout already contains all barndoor control channels.



Barndoors

7.5" Barndoor

The 7.5" Barndoor offers precise control over light direction and spill.



ELA0003 7.5" Barndoor

ELA0004 7.5" Barndoor WH

10" Barndoor

The 10" Barndoor offers precise control over light direction and spill. Crafted with durable materials and a sleek black finish, it effortlessly attaches to compatible lighting fixtures, allowing you to shape and direct light with ease. Its 8-leaf design provides precise control over the beam of light, enabling creative manipulation of shadows and highlights.



ELA0001 10" Barndoor



SixPar/BD100

Barndoor for Sixpar 100 and Sixpar 100IP. Please be aware it can only be used together with the Sixpar 100/GFH (1621000055).



ELA0357 SIXPAR/BD100

SixPar/BD200

Barndoor for Sixpar 200 and Sixpar 200IP. Please be aware it can only be used together with the Sixpar 200/GFH (1621000056).



ELA0358 SIXPAR/BD200

SixPar/BD300

Barndoor for Sixpar 300 and Sixpar 300IP. Please be aware it can only be used together with the Sixpar 300/GFH (1621000057).



ELA0359 SIXPAR/BD300

SL Barndoor (SOL BD)

The SL Barndoor offers precise control over light direction and spill. Crafted with durable materials and a sleek black finish, it effortlessly attaches to compatible lighting fixtures, allowing you to shape and direct light with ease.



ELA0388 S?L Barndoor (SOL BD)

SL Power & DMX Jumper Cable (PDJ112)



ELA0402 S?L Power & DMX Jumper Cable (PDJ112)

PDJ010 25CM Jumper Cable



ELA0212 PDJ010 25CM Jumper Cable

SixPar/10MDLC

IP65, 10m., Male to female data extension cable



- ELA0333 SIXPAR/10MDLC
- ELA0334 SIXPAR/10MDLC/WH
- ELA0337 SIXPAR/1MDLC
- ELA0338 SIXPAR/1MDLC/WH
- ELA0341 SIXPAR/20MDLC
- ELA0342 SIXPAR/20MDLC/WH
- ELA0345 SIXPAR/2MDLC
- ELA0346 SIXPAR/2MDLC/WH
- ELA0349 SIXPAR/35MDLC
- ELA0351 SIXPAR/3MDLC
- ELA0353 SIXPAR/5MDLC
- ELA0354 SIXPAR/5MDLC/WH

Cables

4W Hardwire Plate (HWP404)

The 4W Hardwire Plate is a new concept in fixture engineering. This accessory plate can be easily installed in any compatible fixture to replace the standard 5pin DMX and Locking Power In/Out Connectors with 3m (9.84') long unterminated cables. The cables can be terminated into a junction box for installation, or cable end DMX and Locking Power Connectors of choice can be installed. The 4W Hardwire Plate includes Power In, Power Out, DMX In and DMX Out cables.





ELA0002 4W Hardwire Plate (HWP404)





| SixPar/10MPLC | |
|---|------------------|
| IP65, 10m., Male to female power extension cable | |
|  | |
| ELA0335 | SIXPAR/10MPLC |
| ELA0336 | SIXPAR/10MPLC/WH |
| ELA0339 | SIXPAR/1MPLC |
| ELA0340 | SIXPAR/1MPLC/WH |
| ELA0344 | SIXPAR/20MPLC/WH |
| ELA0347 | SIXPAR/2MPLC |
| ELA0348 | SIXPAR/2MPLC/WH |
| ELA0350 | SIXPAR/35MPLC |
| ELA0352 | SIXPAR/3MPLC |
| ELA0355 | SIXPAR/5MPLC |
| ELA0356 | SIXPAR/5MPLC/WH |

| SixPar/DIAC 5pin | |
|--|------------------|
| This a 5-pin Data In IP Rated Adapter Cable for the SIXPAR IP series of fixtures | |
|  | |
| ELA0360 | SIXPAR/DIAC 5pin |
| ELA0361 | SIXPAR/DIAC 3pin |
| ELA0362 | SIXPAR/DIAC/WH |

| SixPar/DOAC 3pin | |
|---|------------------|
| DATA OUT ADAPTOR CABLE for Sixpar | |
|  | |
| ELA0363 | SIXPAR/DOAC 3pin |
| ELA0364 | SIXPAR/DOAC 5pin |
| ELA0365 | SIXPAR/DOAC/WH |

| SixPar/PIAC | |
|---|----------------|
| Power In ADAPTOR CABLE for Sixpar | |
|  | |
| ELA0366 | SIXPAR/PIAC |
| ELA0367 | SIXPAR/PIAC/WH |

| SixPar/POAC | |
|---|-------------|
| Power OUT ADAPTOR CABLE for Sixpar | |
|  | |
| ELA0368 | SIXPAR/POAC |

| SixPar/Terminator | |
|---|----------------------|
| IP65, Data terminator end cap with 120 ohm resistor inside | |
|  | |
| ELA0369 | SIXPAR/TERMINATOR |
| ELA0370 | SIXPAR/TERMINATOR/WH |

Pixel Bar IP

| Data/Power Cable Pixel Bar IP Ser 0.6m | |
|---|---|
| The DATA/POWER CABLE PIXEL BAR IP SERIES 0.6M™ is a 2 ft (0.6m) IP65 rated 4pin 16AWG shielded power/data cable used exclusively for the PIXEL BAR IP Series. |  |
| ELA0061 | DATA/POWER CABLE PIXEL BAR IP SER. 0,6M |

| Data/Power Cable Pixel Bar IP Ser 1.5m | |
|---|---|
| The DATA/POWER CABLE PIXEL BAR IP SERIES 1.5M™ is a 4.9 ft (1.5m) IP65 rated 4pin 16AWG shielded power/data cable used exclusively for the PIXEL BAR IP Series. |  |
| ELA0062 | DATA/POWER CABLE PIXEL BAR IP SER. 1,5M |

| Data/Power Cable Pixel Bar IP Ser 3.5m | |
|--|---|
| The DATA/POWER CABLE PIXEL BAR IP SERIES 3.5M™ is a 11.5 ft (3.5m) IP65 rated 4pin 16AWG shielded power/data cable used exclusively for the PIXEL BAR IP Series. |  |
| ELA0063 | DATA/POWER CABLE PIXEL BAR IP SER. 3,5M |



Data/Power Cable Pixel Bar IP 4.5m

The DATA/POWER CABLE PIXEL BAR IP SERIES 4.5M™ is a 14.8 ft (4.5m) IP65 rated 4pin 16AWG shielded power/data cable used exclusively for the PIXEL BAR IP Series.



ELA0064 DATA/POWER CABLE PIXEL BAR IP SER. 4,5M

Data/Power Cable Pixel Bar IP Ser 7.5m

The DATA/POWER CABLE PIXEL BAR IP SERIES 7.5M™ is a 24.6 ft (7.5m) IP65 rated 4pin 16AWG shielded power/data cable used exclusively for the PIXEL BAR IP Series.



ELA0065 DATA/POWER CABLE PIXEL BAR IP SERI. 7,5M

Data/Power Cable Pixel Bar IP Series 15m

The DATA/POWER CABLE PIXEL BAR IP SERIES 15M™ is a 49.2 ft (15m) IP65 rated 4pin 16AWG shielded power/data cable used exclusively for the PIXEL BAR IP Series.



ELA0066 DATA/POWER CABLE PIXEL BAR IP SERIES 15M

Data/Power Cable Pixel Bar IP Series 1m

The DATA/POWER CABLE PIXEL BAR IP SERIES 1M™ is a 3.2 ft (1m) IP65 rated 4pin 16AWG shielded power/data cable used exclusively for the PIXEL BAR IP Series.



ELA0067 DATA/POWER CABLE PIXEL BAR IP SERIES 1M

Data/Power Cable Pixel Bar IP Series 3m

The DATA/POWER CABLE PIXEL BAR IP SERIES 3M™ is a 9.8 ft (3m) IP65 rated 4pin 16AWG shielded power/data cable used exclusively for the PIXEL BAR IP Series.



ELA0068 DATA/POWER CABLE PIXEL BAR IP SERIES 3M

Data/Power Cable Pixel Bar IP Series 6m

The DATA/POWER CABLE PIXEL BAR IP SERIES 6M™ is a 19.7 ft (6m) IP65 rated 4pin 16AWG shielded power/data cable used exclusively for the PIXEL BAR IP Series.



ELA0069 DATA/POWER CABLE PIXEL BAR IP SERIES 6M

Data/Power Cable Pixel Bar IP Series 9m

The DATA/POWER CABLE PIXEL BAR IP SERIES 9M™ is a 29.5 ft (9m) IP65 rated 4pin 16AWG shielded power/data cable used exclusively for the PIXEL BAR IP Series.



ELA0070 DATA/POWER CABLE PIXEL BAR IP SERIES 9M

Atmosity Effects Fluids

AAB - Bubble Fluid - 2L

The Atmosity AAB™ is a transparent water-based bubble juice that was formulated to work with most bubble machines. The AAB bubble juice produces hundreds of high-flying bubbles with an average hangtime of 20-30 seconds under optimal conditions. Atmosity AAB Bubble juice bottles are available in 2-litre and 4-litre containers. This bubble juice is pH balanced, colorless, non-toxic, non-irritating, odorless, and eco-friendly. It requires no dilution and is ready for use right out of the container.



ELA0006 AAB - Bubble Fluid - 2L

AAB - Bubble Fluid - 4L

The Atmosity AAB™ is a transparent water-based bubble juice that was formulated to work with most bubble machines. The AAB bubble juice produces hundreds of high-flying bubbles with an average hangtime of 20-30 seconds under optimal conditions. Atmosity AAB Bubble juice bottles are available in 2-litre and 20-litre containers. This bubble juice is pH balanced, colorless, non-toxic, non-irritating, odorless, and eco-friendly. It requires no dilution and is ready for use right out of the container.



ELA0007 AAB - Bubble Fluid - 4L

AAH - Premium Haze Fluid - 20L

The Atmosity Premium Haze Fluid is a water based haze fluid intended to create synthetic atmospheric effects for use with Magmatic Hazer machines - Thermatic™ series, or any other compressor system haze machines that require water based fluid. The Atmosity Premium Haze Fluid is a water-based haze liquid, much drier than the oil-based version. So, this liquid produces virtually no residue. It's Colorless, odorless and non-flammable.



ELA0008 AAH - Premium Haze Fluid - 20L

AAH - Premium Haze Fluid - 2L

The Atmosity Premium Haze Fluid is a water based haze fluid intended to create synthetic atmospheric effects for use with Magmatic Hazer machines - Thermatic™ series, or any other compressor system haze machines that require water based fluid. The Atmosity Premium Haze Fluid is a water-based haze liquid, much drier than the oil-based version. So, this liquid produces virtually no residue. It's Colorless, odorless and non-flammable.



ELA0009 AAH - Premium Haze Fluid - 2L

AAH - Premium Haze Fluid - 4L

The Atmosity Premium Haze Fluid is a water based haze fluid intended to create synthetic atmospheric effects for use with Magmatic Hazer machines - Thermatic™ series, or any other compressor system haze machines that require water based fluid. The Atmosity Premium Haze Fluid is a water-based haze liquid, much drier than the oil-based version. So, this liquid produces virtually no residue. It's Colorless, odorless and non-flammable.



ELA0010 AAH - Premium Haze Fluid - 4L

AEF - Extreme Filtered Fluid - 2L

Atmosity is a high-quality, professional fluid series formulated for use with all types of effect machines. Rigorously tested for consistency and controlled to ensure it is the most pure atmospheric fluid available. Atmosity fluid is treated, filtered and then quality checked for purity, color, density and acidity. The result corresponds to a purity level equivalent to water used by medical laboratories. The Atmosity AEF extreme filtered fog fluid produces dense smoke and haze effects. Formulated for the Magmatic Magma™ series, it can be used in most atmospheric, heater based fog machines.



ELA0011 AEF - Extreme Filtered Fluid - 2L

AEF - Extreme Filtered Fluid - 20L

Atmosity is a high-quality, professional fluid series formulated for use with all types of effect machines. Rigorously tested for consistency and controlled to ensure it is the most pure atmospheric fluid available. Atmosity fluid is treated, filtered and then quality checked for purity, color, density and acidity. The result corresponds to a purity level equivalent to water used by medical laboratories. The Atmosity AEF extreme filtered fog fluid produces dense smoke and haze effects. Formulated for the Magmatic Magma™ series, it can be used in most atmospheric, heater based fog machines.



ELA0012 AEF - Extreme Filtered Fluid - 20L

AEF - Extreme Filtered Fluid - 4L

Atmosity is a high-quality, professional fluid series formulated for use with all types of effect machines. Rigorously tested for consistency and controlled to ensure it is the most pure atmospheric fluid available. Atmosity fluid is treated, filtered and then quality checked for purity, color, density and acidity. The result corresponds to a purity level equivalent to water used by medical laboratories. The Atmosity AEF extreme filtered fog fluid produces dense smoke and haze effects. Formulated for the Magmatic Magma™ series, it can be used in most atmospheric, heater based fog machines.



ELA0013 AEF - Extreme Filtered? Fluid - 4L

AFF - Flash Fog Fluid - 20L

The AFF flash fog fluid by Atmosity is a water-based, fast-dissipating fog fluid specially formulated for the Magmatic Rocket™ series units, as well as most other standard water-based CO2 simulators. With an average hangtime of 10-20 seconds under optimal conditions, the AFF flash fog fluid is specially designed to work with cryogenic simulators for high impact moments. Atmosity AFF Flash Fog Fluid bottles are available in 2-litre, 4-litre, and 20-litre containers. This fog fluid is pH balanced, colorless, non-toxic, non-irritating, and odorless, and it requires no dilution and is ready for use right out of the container.



ELA0014 AFF - Flash Fog Fluid - 20L

AFF - Flash Fog Fluid - 2L

The AFF flash fog fluid by Atmosity is a water-based, fast-dissipating fog fluid specially formulated for the Magmatic Rocket™ series units, as well as most other standard water-based CO2 simulators. With an average hangtime of 10-20 seconds under optimal conditions, the AFF flash fog fluid is specially designed to work with cryogenic simulators for high impact moments. Atmosity AFF Flash Fog Fluid bottles are available in 2-litre, 4-litre, and 20-litre containers. This fog fluid is pH balanced, colorless, non-toxic, non-irritating, and odorless, and it requires no dilution and is ready for use right out of the container.



ELA0015 AFF - Flash Fog Fluid - 2L

AFF - Flash Fog Fluid - 4L

The AFF flash fog fluid by Atmosity is a water-based, fast-dissipating fog fluid specially formulated for the Magmatic Rocket™ series units, as well as most other standard water-based CO2 simulators. With an average hangtime of 10-20 seconds under optimal conditions, the AFF flash fog fluid is specially designed to work with cryogenic simulators for high impact moments. Atmosity AFF Flash Fog Fluid bottles are available in 2-litre, 4-litre, and 20-litre containers. This fog fluid is pH balanced, colorless, non-toxic, non-irritating, and odorless, and it requires no dilution and is ready for use right out of the container.



ELA0016 AFF - Flash Fog Fluid - 4L



ALL - Cryoinc Low Lying Fog Fluid - 20L

The Atmosity ALL™ fluid is a water-based cryogenic fog fluid formulated for the Magmatic line of low-lying fog machines. It has been engineered to produce an artificial, low-lying fog effect for both indoor and outdoor applications. Atmosity ALL™ fog fluid bottles are available in 2-litre, 4-litre, and 20-litre containers. This fog fluid is pH balanced, colorless, non-toxic, non-irritating, and odorless, and it requires no dilutions and is ready for use right out of the container.



ELA0017 | ALL - Cryoinc Low Lying Fog Fluid - 20L

ALL - Cryoinc Low Lying Fog Fluid - 2L

The Atmosity ALL™ fluid is a water-based cryogenic fog fluid formulated for the Magmatic line of low-lying fog machines. It has been engineered to produce an artificial, low-lying fog effect for both indoor and outdoor applications. Atmosity ALL™ fog fluid bottles are available in 2-litre, 4-litre, and 20-litre containers. This fog fluid is pH balanced, colorless, non-toxic, non-irritating, and odorless, and it requires no dilutions and is ready for use right out of the container.



ELA0018 | ALL - Cryoinc Low Lying Fog Fluid - 2L

ALL - Cryoinc Low Lying Fog Fluid - 4L

The Atmosity ALL™ fluid is a water-based cryogenic fog fluid formulated for the Magmatic line of low-lying fog machines. It has been engineered to produce an artificial, low-lying fog effect for both indoor and outdoor applications. Atmosity ALL™ fog fluid bottles are available in 2-litre, 4-litre, and 20-litre containers. This fog fluid is pH balanced, colorless, non-toxic, non-irritating, and odorless, and it requires no dilutions and is ready for use right out of the container.



ELA0019 | ALL - Cryoinc Low Lying Fog Fluid - 4L

APS - Premium Dry Snow Fluid - 20L

The Atmosity APS fluid is a premium, dry-on-impact snow liquid formulated for the Magmatic Polar™ series, as well as most other water-based snow machines. The Atmosity premium snow fluid has been engineered to produce a high volume of realistic snow for both indoor and outdoor applications. Atmosity APS premium dry snow fluid bottles are available in 4-litre and 20-litre containers. This snow fluid is pH balanced, colorless, non-toxic, non-irritating, and odorless, and it requires no dilutions and is ready for use right out of the container.



ELA0020 | APS - Premium Dry Snow Fluid - 20L

APS - Premium Dry Snow Fluid - 4L

The Atmosity APS fluid is a premium, dry-on-impact snow liquid formulated for the Magmatic Polar™ series, as well as most other water-based snow machines. The Atmosity premium snow fluid has been engineered to produce a high volume of realistic snow for both indoor and outdoor applications. Atmosity APS premium dry snow fluid bottles are available in 4-litre and 20-litre containers. This snow fluid is pH balanced, colorless, non-toxic, non-irritating, and odorless, and it requires no dilutions and is ready for use right out of the container.



ELA0021 | APS - Premium Dry Snow Fluid - 4L

ARH - Oil Based Haze Fluid - 20L

The ARH™ fluid by Atmosity is an oil-based haze fluid designed to work with the Magmatic Therma Tour 600, Therma Tour 800, or any other haze machines with a compressor system that require oil-based fluid. This fluid has been specially formulated with advanced fine particulates, which extend the atmospheric linger effect and excels at revealing light beams and mid-air effects. ARH™ fluid bottles are available in 2-litre, 4-litre and 20-litre containers. This haze fluid is colorless, non-toxic, non-irritating, and it requires no dilutions and is ready for use right out of the container.



ELA0022 | ARH - Oil Based Haze Fluid - 20L

ARH - Oil Based Haze Fluid - 2L

The ARH™ fluid by Atmosity is an oil-based haze fluid designed to work with the Magmatic Therma Tour 600, Therma Tour 800, or any other haze machines with a compressor system that require oil-based fluid. This fluid has been specially formulated with advanced fine particulates, which extend the atmospheric linger effect and excels at revealing light beams and mid-air effects. ARH™ fluid bottles are available in 2-litre, 4-litre and 20-litre containers. This haze fluid is colorless, non-toxic, non-irritating, and it requires no dilutions and is ready for use right out of the container.



ELA0023 | ARH - Oil Based Haze Fluid - 2L

ARH - Oil Based Haze Fluid - 4L

The ARH™ fluid by Atmosity is an oil-based haze fluid designed to work with the Magmatic Therma Tour 600, Therma Tour 800, or any other haze machines with a compressor system that require oil-based fluid. This fluid has been specially formulated with advanced fine particulates, which extend the atmospheric linger effect and excels at revealing light beams and mid-air effects. ARH™ fluid bottles are available in 2-litre, 4-litre and 20-litre containers. This haze fluid is colorless, non-toxic, non-irritating, and it requires no dilutions and is ready for use right out of the container.



ELA0024 | ARH - Oil Based Haze Fluid - 4L



Connectors

Connector Panel Cuepix Blinder WW4

Connector panel for Cuepix Blinder WW4 to connect 2 units to each other. Note - Maximum load is only for 2 Cuepix Blinder WW4.



ELA0056

Connector Panel Cuepix Blinder WW4

Connector Panel DTW Blinder V2

Connector Panel to connect 2 DTW Blinder with each other. Fits on both the DTW Blinder 350 IP and the DTW Blinder 700 IP. It's also possible to combine the DTW Blinder 350 IP with the DTW Blinder 700 IP.
Note - Maximum load is only for 2 DTW Blinder 700 OR 3 DTW Blinder 350 units.



ELA0057

Connector Panel DTW Blinder V2

Fixture Interconnect Splice Package

Package of 6 Fixture Interconnect Splices. Compatible with: SIX+ BAR S, SIX+ BAR L, PULSE BAR S, PULSE BAR L, PULSE PANEL, SL II Blinder, SL IV Blinder, SL I Blinder Frame.



ELA0085

Fixture Interconnect Splice Package

SL I Interconnect (SOL1 IC)



ELA0396

S?L I Interconnect (SOL1 IC)

SL I M10 Connect (SOL1 M10C)



ELA0398

S?L I M10 Connect (SOL1 M10C)

SL I Interconnect Pack

The SL I Interconnect Pack includes 6 of the SL I Interconnect accessories to allow the assembly of more complex configurations



and arrays using the SL I BLINDER.
It offers a maximum suspension limit of 40.8kg (90lbs) in a vertical orientation, and when the orientation deviates from vertical, the maximum suspension limit for the Fixture Interconnect decreases to 13.8kg (30.5lbs), which includes all accessories, cables, and rigging hardware attached to the fixture array.







Light Shaping Filter LSF30-24 30°

Light Shaping Filters from Elation are easy-to-use poly carbonate sheets which can be cut to size to fit over any LED fixture and transmit up to 92% of the light, shaping it to the desired effect you want. You can smooth or widen out any LED Panel or Par while also improving the field of color or turn you LED Par can into a wall washer. Each sheet measures 508 x 609 mm. If outfitting a 10cm LED par can, for example, 30 filters could be cut from a 508 x 609 mm sheet, making the cost per fixture even more affordable.



ELA0170 Light Shaping Filter LSF30-24 30°

Lenses

Designlens for DTW Blinder



ELA0071 Designlens for DTW Blinder

SIX+L GFK

The SIX+L GFK is an optional accessory kit that includes a gel frame holder and front bumper assembly that easily attaches to the SIX+ PAR L fixture, and a gel frame that easily slides into the holder. The SIX+L GFK accepts any 10" frame size accessory.



ELA0309 SIX+L GFK

FW500 Ovalizer



Light Shaping Filter LSF10-24 10°

Light Shaping Filters from Elation are easy-to-use poly carbonate sheets which can be cut to size to fit over any LED fixture and transmit up to 92% of the light, shaping it to the desired effect you want. You can smooth or widen out any LED Panel or Par while also improving the field of color or turn you LED Par can into a wall washer. Each sheet measures 609 x 609 mm. If outfitting a 10cm LED par can, for example, 36 filters could be cut from a 609 x 609 mm sheet, making the cost per fixture even more affordable.



ELA0168 Light Shaping Filter LSF10-24 10°

SIX+L L1060

The SIX+L L1060 lens provides even and soft coverage with a 10°x 60° elliptical beam for use in the SIX+ PAR L fixture. The lens is rotatable to the desired position.



ELA0310 SIX+L L1060

SIX+L L140

The SIX+L L140 provides even and soft coverage with a 1°x 40° elliptical beam for use in the SIX+ PAR L fixture. The lens is rotatable to the desired position.



ELA0311 SIX+L L140

Light Shaping Filter LSF20-22 20°

Light Shaping Filters from Elation are easy-to-use poly carbonate sheets which can be cut to size to fit over any LED fixture and transmit up to 92% of the light, shaping it to the desired effect you want. You can smooth or widen out any LED Panel or Par while also improving the field of color or turn you LED Par can into a wall washer. Each sheet measures 558 x 609 mm. If outfitting a 10cm LED par can, for example, 30 filters could be cut from a 558 x 609 mm sheet, making the cost per fixture even more affordable.



ELA0169 Light Shaping Filter LSF20-22 20°

SIX+L WFL

The SIX+L (wide flood) lens provides even and soft coverage with a 60° Beam Angle for use in the SIX+ PAR L fixture.





ELA0312 SIX+L WFL





| | |
|--|---|
| SIX+L XFL | |
| <p>The SIX+L XFL (Extra-wide flood) lens provides even and soft coverage with a 100° Beam Angle for use in the SIX+ PAR L fixture.</p> |  |
| ELA0313 | SIX+L XFL |

| | |
|---|---|
| SIX+S WFL | |
| <p>The SIX+S WFL (wide flood) lens provides even and soft coverage with a 60° Beam Angle for use in the SIX+ PAR S fixture.</p> |  |
| ELA0317 | SIX+S WFL |

| | |
|---|---|
| SIX+S GFK | |
| <p>The SIX+S GFK is an optional accessory kit that includes a gel frame holder and front bumper assembly that easily attaches to the SIX+ PAR S fixture, and a gel frame that easily slides into the holder. The SIX+S GFK accepts any 7.5" frame size accessory.</p> |  |
| ELA0314 | SIX+S GFK |

| | |
|--|---|
| SIX+L XFL | |
| <p>The SIX+L XFL (Extra-wide flood) lens provides even and soft coverage with a 100° Beam Angle for use in the SIX+ PAR L fixture.</p> |  |
| ELA0318 | SIX+S XFL |

| | |
|--|--|
| Light Shaping Filter LSF601-24 60°x1° | |
| <p>Light Shaping Filters from Elation are easy-to-use poly carbonate sheets which can be cut to size to fit over any LED fixture and transmit up to 92% of the light, shaping it to the desired effect you want. You can smooth or widen out any LED Panel or Par while also improving the field of color or turn you LED Par can into a wall washer with our linear 60 x 1 degree filter. Each sheet measures 508 x 609 mm. If outfitting a 15cm LED par can, for example, 12 filters could be cut from a 508 x 609 mm sheet, making the cost per fixture even more affordable.</p> |  |
| ELA0171 | Light Shaping Filter LSF601-24 60°x1° |

| | |
|---|---|
| PC lens assembly of Rembrandt | |
| <p>This is an optional PC lens assembly for the Artiste Rembrandt fixture. The Fresnel lens supplied with the fixture is interchangeable with this Pebble Convex lens - the PC providing a tighter beam angle and higher center intensity for long throws or beam applications.</p> |  |
| ELA0211 | PC lens assembly of Rembrandt |

| | |
|---|---|
| SIX+S L1060 | |
| <p>The SIX+S L1060 lens provides even and soft coverage with a 10°x 60° elliptical beam for use in the SIX+ PAR S fixture. The lens is rotatable to the desired position.</p> |  |
| ELA0315 | SIX+S L1060 |

| | |
|---|---|
| SL Dome Lens | |
| <p>The SL Dome Lens for the SL Blinder serves as a visually transformative tool, softening and diffusing the fixture's intense light output with a gentle, flattering effect while also adding an additional dimension of character with its dome shape. This modification is particularly valuable in scenarios where harsh brightness needs to be minimized, or where a more subtle, ambient illumination or visual element is desired. The SL Dome Lens offers even more flexible options to transform the look of the SL Blinder.</p> |  |
| ELA0390 | S?L Dome Lens |

| | |
|--|---|
| SIX+S L140 | |
| <p>The SIX+S L140 provides even and soft coverage with a 1°x 40° elliptical beam for use in the SIX+ PAR S fixture. The lens is rotatable to the desired position.</p> |  |
| ELA0316 | SIX+S L140 |

| | |
|---------------------------------|---|
| SL Fresnel Lens (SOL FL) | |
| |  |
| ELA0391 | S?L Fresnel Lens (SOL FL) |

| | |
|--|--|
| SL Blackout Lens | |
| <p>The SL Blackout Lens enhances the versatility of the SL BLINDER by reducing its output, making it ideal for light-sensitive</p> | |



environments. Compatible with SL BLINDER
I, II and IV







Fuze Pendant Lenses

Fuze Pendant Lens 25°

An alternative 25° lens to install in the Fuze Pendant - easy to install within seconds.



ELA0104 | Fuze Pendant Lens 25°

Fuze Pendant Lens 40°

An alternative 40° lens to install in the Fuze Pendant - easy to install within seconds.



ELA0105 | Fuze Pendant Lens 40°

Fuze Pendant Lens 50°

An alternative 50° lens to install in the Fuze Pendant - easy to install within seconds.



ELA0106 | Fuze Pendant Lens 50°

KL Lenses

KL Par FC Glass Lens

The KL PAR Glass lens replicates the iconic PAR lens look inside the fixture. The facets create a slightly elliptical beam spread, and the lens is rotatable to the desired position.



ELA0159 | KL PAR FC Glass Lens

KL Par XWFL Lens

The KL PAR XWFL (extra wide flood) lens provides even and soft coverage with a 92° Beam Angle. This is an accessory lens to fit the KL Par, it slots onto the unit easily in seconds with no special tools needed.



NOTE: Image for illustrative purposes, actual product may vary

ELA0162 | KL PAR XWFL LENS

KL Profile FC Fresnel Lens

The KL Profile FC Fresnel Lens is an optional accessory lens which offers the ability to convert the KL Profile FC from its native projection optic to a smooth Fresnel wash.



ELA0164 | KL Profile FC Fresnel Lens

14 Degree IP Lens Tube

The 14 Degree IP Lens Tube represents a leap forward in ellipsoidal lens design, offering advanced features for unmatched performance. With a sealed internal lens assembly, it protects the optical path from dust, debris, and liquids, ensuring a consistently clean and efficient light output. Its IP67 rating guarantees long-lasting, bright performance, even in challenging environments. Designed for maximum optical efficiency, the lens tube delivers exceptional output without compromise. Compatible with any fixture that accepts industry-standard lens tubes, it offers unparalleled versatility. Additionally, the durable C4 Marine Coating ensures reliable operation in both indoor and outdoor settings.



19 Degree IP Lens Tube

The 19 Degree IP Lens Tube represents a leap forward in ellipsoidal lens design, offering advanced features for unmatched performance. With a sealed internal lens assembly, it protects the optical path from dust, debris, and liquids, ensuring a consistently clean and efficient light output. Its IP67 rating guarantees long-lasting, bright performance, even in challenging environments. Designed for maximum optical efficiency, the lens tube delivers exceptional output without compromise. Compatible with any fixture that accepts industry-standard lens tubes, it offers unparalleled versatility. Additionally, the durable C4 Marine Coating ensures reliable operation in both indoor and outdoor settings.



Placeholder image
Actual photo coming soon

26 Degree IP Lens Tube

The 26 Degree IP Lens Tube represents a leap forward in ellipsoidal lens design, offering advanced features for unmatched performance. With a sealed internal lens assembly, it protects the optical path from dust, debris, and liquids, ensuring a consistently clean and efficient light output. Its IP67 rating guarantees long-lasting, bright performance, even in challenging environments. Designed for maximum optical



efficiency, the lens tube delivers exceptional output without compromise. Compatible with any fixture that accepts industry-standard lens tubes, it offers unparalleled versatility. Additionally, the durable C4 Marine Coating ensures reliable operation in both indoor and outdoor settings.



Placeholder image
Actual photo coming soon

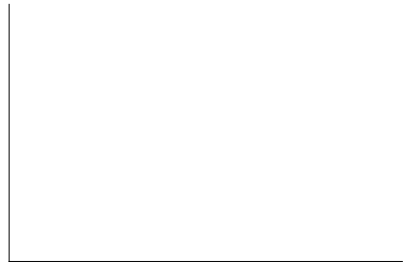



36 Degree IP Lens Tube

The 36 Degree IP Lens Tube represents a leap forward in ellipsoidal lens design, offering advanced features for unmatched performance. With a sealed internal lens assembly, it protects the optical path from dust, debris, and liquids, ensuring a consistently clean and efficient light output. Its IP67 rating guarantees long-lasting, bright performance, even in challenging environments. Designed for maximum optical efficiency, the lens tube delivers exceptional output without compromise. Compatible with any fixture that accepts industry-standard lens tubes, it offers unparalleled versatility. Additionally, the durable C4 Marine Coating ensures reliable operation in both indoor and outdoor settings.



50 Degree IP Lens Tube

The 50 Degree IP Lens Tube represents a leap forward in ellipsoidal lens design, offering advanced features for unmatched performance. With a sealed internal lens assembly, it protects the optical path from dust, debris, and liquids, ensuring a consistently clean and efficient light output. Its IP67 rating guarantees long-lasting, bright performance, even in challenging environments. Designed for maximum optical efficiency, the lens tube delivers exceptional output without compromise. Compatible with any fixture that accepts industry-standard lens tubes, it offers unparalleled versatility. Additionally, the durable C4 Marine Coating ensures reliable operation in both indoor and outdoor settings.



70 Degree IP Lens Tube

The 70 Degree IP Lens Tube represents a leap forward in ellipsoidal lens design, offering advanced features for unmatched performance. With a sealed internal lens assembly, it protects the optical path from dust, debris, and liquids, ensuring a consistently clean and efficient light output. Its IP67 rating guarantees long-lasting, bright performance, even in challenging environments. Designed for maximum optical efficiency, the lens tube delivers exceptional output without compromise. Compatible with any fixture that accepts industry-standard lens tubes, it offers unparalleled versatility. Additionally, the durable C4 Marine Coating ensures reliable operation in both indoor and outdoor settings.



Paladin Filters

Paladin Brick Filter 100°



ELA0190 | Paladin Brick Filter 100°

Paladin Brick Filter 10X60°



ELA0191 | Paladin Brick Filter 10X60°

Paladin Brick Filter 1X40°



ELA0192 | Paladin Brick Filter 1X40°

Paladin Brick Filter 20°



ELA0193 | Paladin Brick Filter 20°

Paladin Brick Filter 40X1°





ELA0194 | Paladin Brick Filter 40X1°





| | |
|------------------------------------|---|
| Paladin Brick Filter 60X10° | |
| |  |
| ELA0195 | Paladin Brick Filter 60X10° |

| | |
|-----------------------------------|---|
| Paladin Cube Filter 60X10° | |
| |  |
| ELA0201 | Paladin Cube Filter 60X10° |

| | |
|---------------------------------|---|
| Paladin Brick Filter 60° | |
| |  |
| ELA0196 | Paladin Brick Filter 60° |

| | |
|--------------------------------|---|
| Paladin Cube Filter 60° | |
| |  |
| ELA0202 | Paladin Cube Filter 60° |

| | |
|---------------------------------|--|
| Paladin Cube Filter 100° | |
| |  |
| ELA0198 | Paladin Cube Filter 100° |

| | |
|----------------------------------|--|
| Paladin Panel Filter 100° | |
| |  |
| ELA0204 | Paladin Panel Filter 100° |

| | |
|--------------------------------|---|
| Paladin Cube Filter 20° | |
| |  |
| ELA0199 | Paladin Cube Filter 20° |

| | |
|------------------------------------|---|
| Paladin Panel Filter 10X60° | |
| |  |
| ELA0205 | Paladin Panel Filter 10X60° |

| | |
|----------------------------------|---|
| Paladin Cube Filter 40X1° | |
| |  |
| ELA0200 | Paladin Cube Filter 40X1° |

| | |
|-----------------------------------|---|
| Paladin Panel Filter 1X40° | |
| |  |
| ELA0206 | Paladin Panel Filter 1X40° |



| | |
|---------------------------------|---|
| Paladin Panel Filter 20° | |
| |  |
| ELA0207 | Paladin Panel Filter 20° |

| | |
|-----------------------------------|---|
| Paladin Panel Filter 40X1° | |
| |  |
| ELA0208 | Paladin Panel Filter 40X1° |

| | |
|------------------------------------|--|
| Paladin Panel Filter 60X10° | |
| |  |
| ELA0209 | Paladin Panel Filter 60X10° |

| | |
|---------------------------------|---|
| Paladin Panel Filter 60° | |
| |  |
| ELA0210 | Paladin Panel Filter 60° |

PARAGON Lenses

| | |
|--------------------------|---|
| PARAGON S PC Lens | |
| PARAGON S PC Lens |  |

| | |
|-------------------------------|---|
| PARAGON S Fresnel Lens | |
| PARAGON S Fresnel Lens |  |





PARAGON M PC Lens

PARAGON M PC Lens



PARAGON M Fresnel Lens

PARAGON M Fresnel Lens



PARAGON S Snoot

PARAGON S Snoot



PARAGON M Snoot

PARAGON M Snoot



Power Supply

FLEX PSU4A

Power supply for single Flex LED Tape WP



ELA0092

FLEX PSU4A

Fuze Accessories

Fuze Pendant Ceiling Mount Kit

This easy to install kit gives your Fuze Pendant the ability to be recessed into a ceiling for a professional installation. Other optional accessories (including a Yoke Mount Kit) are available for the Fuze Pendant - See below in Related Products. Installation instructions can be found below.



ELA0100

Fuze Pendant Ceiling Mount Kit

Fuze Pendant Full Snoot

This full snoot attaches to the Fuze pendant in seconds & allows greater control of the direction and radius of the beam. Other optional accessories (including a Half Snoot) are available for the Fuze Pendant - See below in Related Products.



ELA0102

Fuze Pendant Full Snoot

Fuze Pendant Half Snoot

This half snoot attaches to the Fuze pendant in seconds & allows greater control of the direction and radius of the beam. Other optional accessories (including a Full Snoot) are available for the Fuze Pendant - See below in Related Products.



ELA0103

Fuze Pendant Half Snoot

Fuze Pendant Yoke Mount Kit

This easy to install kit gives your Fuze Pendant a fully functional yoke for greater versatility for positioning & focusing.





ELA0108

Fuze Pendant Yoke Mount Kit



Seven Batten Accessories

| | |
|--|---|
| Glareshield Seven Batten 14 | |
| This glareshield installs in seconds onto your Seven Batten 14 unit, giving you further control of the light distribution. |  |
| ELA0124 | Glareshield Seven Batten 14 |

| | |
|--|---|
| Glareshield Seven Batten 42 | |
| This glareshield installs in seconds onto your Seven Batten 42 unit, giving you further control of the light distribution. |  |
| ELA0125 | Glareshield Seven Batten 42 |

| | |
|--|---|
| Glareshield Seven Batten 72 | |
| This glareshield installs in seconds onto your Seven Batten 72 unit, giving you further control of the light distribution. |  |
| ELA0126 | Glareshield Seven Batten 72 |

KL Panel Accessories

| | |
|---|--|
| KL Panel Intensifier Lens | |
| The KL Panel Intensifier Lens is optimized to shape the output of the fixture when a higher center intensity is required. This lens provides a 50° beam and 89° field angle and increases the center intensity by over 30%. It is an easy drop in replacement for the standard diffuser. Optimized for the KL Panel it helps utilize the fixture at longer distances or to increase output while keeping the field smooth for perfect illumination. |  <small>Panel not included</small> |
| ELA0150 | KL Panel Intensifier Lens |

| | |
|---|---|
| KL Panel Narrow Yoke | |
| The KL Panel Narrow Yoke is a yoke that makes it possible to position the KL Panel practically anywhere, including vertically. The KL Panel Narrow Yoke, which slides onto the rail mounting system on the rear of the KL Panel, replaces the regular Yoke. |  |
| ELA0151 | KL Panel Narrow Yoke |

| | |
|---|---|
| KL Panel Pole Operation Bracket | |
| This is an accessory Pole Operation Bracket kit for the KL Panel. It replaces the standard Yoke to allow for pole operation in a studio environment. It installs easily within minutes. |  |
| ELA0152 | KL Panel Pole Operation Bracket |

| | |
|---|---|
| KL Panel XL Intensifier Lens | |
| The KL Panel XL Intensifier Lens is optimized to shape the output of the fixture when a higher center intensity is required. This lens provides a 50° beam and 89° field angle and increases the center intensity by over 30%. It is an easy drop in replacement for the standard diffuser. Optimized for the KL Panel XL it helps utilize the fixture at longer distances or to increase output while keeping the field smooth for perfect illumination. |  <small>Panel not included</small> |
| ELA0154 | KL Panel XL Intensifier Lens |

| | |
|---|--|
| KL Panel XL IP Intensifier Lens | |
| The KL Panel XL IP Intensifier Lens is optimized to shape the output of the fixture when a higher center intensity is required. It is an easy drop in replacement for the standard diffuser. Optimized for the KL Panel XL IP it helps utilize the fixture at longer distances or to increase output while keeping the field smooth for perfect illumination. |  <small>Panel not included</small> |
| ELA0156 | KL Panel XL IP Intensifier Lens |

| | |
|--|---|
| KL Panel XL Pole Operation Bracket | |
| This is an accessory Pole Operation Bracket kit for the KL Panel XL. It replaces the standard Yoke to allow for pole operation in a studio environment. It installs easily within minutes. |  |
| ELA0157 | KL Panel XL Pole Operation Bracket |



Snapbags & Snapgrids

Snapbag KL Panel XL IP

This is a softbox accessory that fits directly and easily onto the KL Panel XL IP. This durable SNAPBAG offers control of the spread of the light. It snaps out of its compact pouch ready to easily attach via elastic straps to the corners of the KL panel XL IP.



ELA0376 | SNAPBAG KL Panel XL IP

Snapbag KL Panel

This is a softbox accessory that fits directly and easily onto the KL Panel. This durable SNAPBAG offers control of the spread of the light. It snaps out of its compact pouch ready to easily attach via elastic straps to the corners of the KL panel.



Panel not included

ELA0377 | SNAPBAG KL-PANEL

Snapbag KL Panel XL

This is a softbox accessory that fits directly and easily onto the KL Panel XL. This durable SNAPBAG offers control of the spread of the light. It snaps out of its compact pouch ready to easily attach via elastic straps to the corners of the KL panel XL.



ELA0378 | SNAPBAG KL-PANEL XL

Snapbag Universal KL Fresnel

This is a softbox accessory that fits directly and easily onto the KL Fresnel 6 & 8 range of fixtures.



Fresnel not included

ELA0379 | SNAPBAG UNIVERSAL KL FRESNEL

Snapgrid 40° f. Snapbag KL Panel XL/XLIP

This is a 40° Snapgrid for the KL Panel XL / XL IP to work only with the related KL Panel XL / XL IP Snapbag Softbox.



ELA0380 | SNAPGRID 40° f. SNAPBAG KL PANEL XL/XLIP

Snapgrid 40° for Snapbag KL Panel

This is a 40° Snapgrid for the KL Panel to work only with the related KL Snapbag Softbox.



ELA0381 | SNAPGRID 40° for SNAPBAG KL PANEL

Snapgrid 40° KL Panel XL IP

This is a 40° accessory SNAPGRID that fits directly and easily onto the KL Panel XL IP. This durable SNAPGRID offers control of the spread of the light. It snaps out of its compact pouch ready to easily attach via elastic straps to the corners of the KL panel XL IP.



ELA0382 | SNAPGRID 40° KL Panel XL IP

Snapgrid 40° KL-Panel XL

This is a 40° accessory SNAPGRID that fits directly and easily onto the KL Panel XL. This durable SNAPGRID offers control of the spread of the light. It snaps out of its compact pouch ready to easily attach via elastic straps to the corners of the KL panel XL.



Panel not included

ELA0384 | SNAPGRID 40° KL-PANEL XL

Snapgrid 40° Snapbag Universal KL Fresnel

This is a 40° Snapgrid for the KL Fresnel 6 & 8 Series to work only with the related SNAPBAG UNIVERSAL KL FRESNEL Softbox.



ELA0385 | SNAPGRID 40° SNAPBAG Universal KL Fresnel

Snapgrid 40° KL-Panel

This is a 40° accessory SNAPGRID that fits directly and easily onto the KL Panel. This durable SNAPGRID offers control of the spread of the light. It snaps out of its compact pouch ready to easily attach via elastic straps to the corners of the KL panel.



Panel not included

ELA0383 | SNAPGRID 40° KL-PANEL



Snapgrid 40° TVL- Softlight DW

TVL SOFTLIGHT DW SNAPGRID 40 is designed exclusively for the ELATION TVL SOFTLIGHT DW. It easily attaches to the front of the TVL SOFTLIGHT DW to effectively reduce the light output spread from 115° to 40°. Taking full advantage of DoPchoice's patented instant set-up and self-tightening internal SNAPFRAMES, it practically snaps out of its compact pouch ready to easily attaches via hefty elastic straps to the corners of the TVL SOFTLIGHT DW.



ELA0386 | SNAPGRID 40° TVL- Softlight DW

Snapgrid 40° TVL-Panel DW

TVL PANEL DW SNAPGRID 40 is designed exclusively for the ELATION TVL PANEL DW. It easily attaches to the front of the TVL PANEL DW to effectively reduce the light output spread from 115° to 40°. Taking full advantage of DoPchoice's patented instant set-up and self-tightening internal SNAPFRAMES, it practically snaps out of its compact pouch ready to easily attaches via hefty elastic straps to the corners of the TVL PANEL DW.



ELA0387 | SNAPGRID 40° TVL-Panel DW

SixPar Gel Frame Kits

SixPar100/GFH

Note - For cutting filter/gel the frame is 197mm by 197mm (with rounded corners)



ELA0371 | SIXPAR100/GFH

SixPar200/GFH

Note - For cutting filter/gel the frame is 245mm by 245mm (with rounded corners)



ELA0372 | SIXPAR200/GFH

SixPar300/GFH

Note - For cutting filter/gel the frame is 297mm by 297mm (with rounded corners)



ELA0373 | SIXPAR300/GFH

Profile Lenses

PHDL19

The Profile HD 19 Degree Lens is a high definition enhanced output lens designed to fit all Elation Profile ellipsoidal models. The lens features dual advanced fixed length aspheric lenses with a non-glare coating, and integrated 6.25" (159mm) gel frame holder (gel frame not included), and a rugged die-cast aluminum housing.



LENS OPTIONS (SOLD SEPARATELY)
19° / 26° / 36° / 50°

ELA0213 | PHDL19

ELA0214 | PHDL26

ELA0215 | PHDL36

ELA0216 | PHDL50

Chorus Line

Chorus Line 16

CHORUS LINE 16™ is a 16 pixel bar wash luminaire featuring 40W 4-in-1 RGBW LEDs, motorized 4° to 40° zoom and 220° tilt movement, full pixel control, 2,700K - 7,000K adjustable linear color temperature, 64 color presets and 14 unique color macros, electronic strobe and 16-bit variable dimming curve modes, adjustable LED refresh rate frequency and gamma brightness for flicker free operation for TV and FILM, DMX, RDM, Kling-NET, and Art-NET protocol support, DMX, RJ45 ethernet, and Locking Power Cable in/out connections, 4 button LCD control panel display, dual quick-lock omega bracket rigging, and a multi-voltage universal auto switching power supply (100-240v).



ELA0049 | CHORUS LINE 16

Chorus Line 8

CHORUS LINE 8™ is a 8 pixel bar wash luminaire featuring 40W 4-in-1 RGBW LEDs, motorized 4° to 40° zoom and 220° tilt movement, full pixel control, 2,700K - 7,000K adjustable linear color temperature, 64 color presets and 14 unique color macros, electronic strobe and 16-bit variable dimming curve modes, adjustable LED refresh rate frequency and gamma brightness for flicker free operation for TV and FILM, DMX, RDM, Kling-NET, and Art-NET protocol support, DMX, RJ45 ethernet, and Locking Power Cable in/out connections, 4 button LCD control panel display, dual quick-lock omega bracket rigging, and a multi-voltage universal auto switching power supply (100-240v).



ELA0050 | CHORUS LINE 8



Flex

Flex Pixel 5V/6A PSU

To be used as the Power Supply for the Flex Pixel P14WP or Flex Pixel P40WP products, It accepts an incoming voltage of 100-240VAC.



ELA0087

Flex Pixel 5V/6A PSU

Flex Pixel Driver1

Flex Pixel Driver is a dedicated DMX driver for up to 144 Pixels / 2 Tapes / up to 432 DMX channels of control. It's small, compact design allows for easy mounting and integration into your installation.



ELA0088

Flex Pixel Driver1

Flex Pixel IRC

The Flex Pixel IR Infrared Wireless Receiver & Remote driver allows for stand alone control of the Flex Pixel WP Tape



ELA0089

Flex Pixel IRC

Flex Pixel P14WP

The FLEX PIXEL P14WP™ is an outdoor rated 6.6 foot (2m) flexible LED pixel tape featuring (144) RGB SMD tri-color LED pixels (432 total DMX channels) spaced on 0.55" (14mm) centers, producing over 1 billion color possibilities with a 120° viewing angle, enclosed in an IP65 rated waterproof flexible cover which can be cut and extended every 2" (51mm), and mountable to most surfaces.



ELA0090

Flex Pixel P14WP

Flex Pixel P40WP

The FLEX PIXEL P40WP™ is an outdoor rated 10 foot (3m) flexible LED pixel tape featuring (72) RGB SMD tri-color LED pixels (216 total DMX channels) spaced on 1.6" (40mm) centers, producing over 1 billion color possibilities with a 120° viewing angle, enclosed in an IP65 rated waterproof flexible cover which can be cut and extended every 4" (102mm), and mountable to most surfaces.



ELA0091

Flex Pixel P40WP

Dartz

Dartz 360

The DARTZ 360™ is a unique, compact, narrow beam luminaire featuring a new patent pending single source 50W RGB LED engine producing an impressive 3° aperture, amazing high output level, and smooth color-mixed effects that can be used in a variety of applications requiring no minimum safe project distance as with typical discharge lamp beam fixtures, fast and precise 16-bit continuous 360° pan and tilt rotation, 14 static-stamped metal gobos, 6-facet linear and 8-facet independent rotating prisms, 0-100% linear frost filter for wash effects, high speed electronic shutter and strobe, electronic dimming and variable dimming curve modes, adjustable LED refresh rate and gamma brightness for flicker free operation for TV and FILM, DMX, RDM (Remote Device Management), Kling-Net, Art-NET, and sACN protocol support, Elation's E-FLY™ internal wireless DMX transceiver, 5pin XLR, RJ45 ethernet, and Locking Power Cable in/out connections, full color 180° reversible menu display with multi-button c



ELA0060

DARTZ 360

DW Chorus

DW Chorus 12

The DW Chorus™ series is available in 1 (0.3m), 2 (0.6m), 4 (1.2m), and 6 foot (1.8m) fixture lengths, featuring long life individual Lumi™ 3W LEDs, 100,000 average hour LED life*, LED group control, variable dimming curve modes, variable white color temperature (2,700K - 6,700K), strobe and chase effects, ArtNet™, KlingNet™ and RDM (remote device management) protocol support, locking 3pin and 5pin XLR DMX, power, and RJ45 Ethernet in/out connections, LCD menu display with 4 button control panel, integrated rigging brackets, multiple unit power linking, rugged die-cast aluminum exterior, flicker free operation for TV and FILM, and a multi-voltage universal auto switching power supply (110-240v).



ELA0076

DW CHORUS 12

DW Chorus 24

The DW Chorus™ series is available in 1 (0.3m), 2 (0.6m), 4 (1.2m), and 6 foot (1.8m) fixture lengths, featuring long life individual Lumi™ 3W LEDs, 100,000 average hour LED life*, LED group control, variable dimming curve modes, variable white color temperature (2,700K - 6,700K), strobe and chase effects, ArtNet™, KlingNet™ and RDM (remote device management) protocol support, locking 3pin and 5pin XLR DMX, power, and RJ45 Ethernet in/out connections, LCD menu display with 4 button control panel, integrated rigging brackets, multiple unit power linking, rugged die-cast aluminum exterior, flicker free operation for TV and FILM, and a multi-voltage universal auto switching power supply (110-240v).



ELA0077

DW CHORUS 24



DW Chorus 48

The DW Chorus™ series is available in 1 (0.3m), 2 (0.6m), 4 (1.2m), and 6 foot (1.8m) fixture lengths, featuring long life individual Lumi™ 3W LEDs, 100,000 average hour LED life*, LED group control, variable dimming curve modes, variable white color temperature (2,700K - 6,700K), strobe and chase effects, ArtNet™, KlingNet™ and RDM (remote device management) protocol support, locking 3pin and 5pin XLR DMX, power, and RJ45 Ethernet in/out connections, LCD menu display with 4 button control panel, integrated rigging brackets, multiple unit power linking, rugged die-cast aluminum exterior, flicker free operation for TV and FILM, and a multi-voltage universal auto switching power supply (110-240v).



ELA0078 DW CHORUS 48

DW Chorus 72

The DW Chorus™ series is available in 1 (0.3m), 2 (0.6m), 4 (1.2m), and 6 foot (1.8m) fixture lengths, featuring long life individual Lumi™ 3W LEDs, 100,000 average hour LED life*, LED group control, variable dimming curve modes, variable white color temperature (2,700K - 6,700K), strobe and chase effects, ArtNet™, KlingNet™ and RDM (remote device management) protocol support, locking 3pin and 5pin XLR DMX, power, and RJ45 Ethernet in/out connections, LCD menu display with 4 button control panel, integrated rigging brackets, multiple unit power linking, rugged die-cast aluminum exterior, flicker free operation for TV and FILM, and a multi-voltage universal auto switching power supply (110-240v).



ELA0079 DW CHORUS 72

Pro Case 1x Proteus Hybrid FI

Pro Case 1x Proteus Hybrid FI

NEW



ELA0248 Pro Case 1x Proteus Hybrid FI

Pro Case 2 X Fuze Spot / Profile

Pro Case 2 X Fuze Spot / Profile

NEW



ELA0249 Pro Case 2 X Fuze Spot / Profile

Pro Case 2 X Proteus Rayzor 760 FI

Pro Case 2 X Proteus Rayzor 760 FI

NEW



ELA0250 Pro Case 2 X Proteus Rayzor 760 FI

Pro Case 2X Fuze Wash Z120

Pro Case 2X Fuze Wash Z120

NEW



Example only

ELA0251 Pro Case 2X Fuze Wash Z120

Pro Case 2X Fuze Wash Z350

Pro Case 2X Fuze Wash Z350

NEW



Example only

ELA0252 Pro Case 2X Fuze Wash Z350

Cases Pro Case

Pro Case 1 X Artiste Monet FI

Pro Case 1 X Artiste Monet FI

NEW



ELA0246 Pro Case 1 X Artiste Monet FI

Pro Case 1 X Proteus Maximus FI

Pro Case 1 X Proteus Maximus FI

NEW



ELA0247 Pro Case 1 X Proteus Maximus FI



Pro Case 4x DARTZ 360

Measurements: 800x650x540mm excl. wheels FEATURES• 9,5mm Birch plywood with special foil• 35mm Aluminum-edge protection• Medium sized ball corners• 2 Large butterfly catches• 2 Large lid stays with hinge• 2 Large sized handles at each side• All Inserts made of 6,5mm birch plywood, solid riveted• 4 Swivel castor 100mm Blue wheels (2 with brakes), home brand, made in Germany• 1 Unpadded accessory tray, at least 100mm wide• Device-specific padded compartments• Inlet shell in ...



ELA0253 Pro Case 4x DARTZ 360

Pro Case for 3 X Chorus Line 16

Pro Case for 3 X Chorus Line 16



ELA0258 Pro Case for 3 X Chorus Line 16

Pro Case for 2x Fuze SFX

Pro Case for 2x Fuze SFX



ELA0255 Pro Case for 2x Fuze SFX

Pro Case for 3 X Chorus Line 8

Touring Case for 3 X Chorus Line 8



ELA0259 Pro Case for 3 X Chorus Line 8

Pro Case for 2x Smarty MAX FI

Pro Case for 2x Smarty MAX FI



ELA0257 Pro Case for 2x Smarty MAX FI

Pro Case for 4 X DTW Blinder 700 IP

Pro Case for 4 X DTW Blinder 700 IP



ELA0260 Pro Case for 4 X DTW Blinder 700 IP

Pro Case for 2x Artiste Picasso FI

Pro Case for 2x Artiste Picasso FI



ELA0254 Pro Case for 2x Artiste Picasso FI

Pro Case for 6 X Chorus Line 8

Pro Case for 6 X Chorus Line 8



ELA0261 Pro Case for 6 X Chorus Line 8

Pro Case for 2x Smarty Hybrid FI

Pro Case for 2x Smarty Hybrid FI



ELA0256 Pro Case for 2x Smarty Hybrid FI

Pro Case for 6 X DTW Blinder 350 IP

Pro Case for 6 X DTW Blinder 350 IP



ELA0262 Pro Case for 6 X DTW Blinder 350 IP



Pro Case for 6 X DTW Blinder 700 IP

Pro Case for 6 X DTW Blinder 700 IP

NEW



Example only

ELA0263

Pro Case for 6 X DTW Blinder 700 IP

Touring Case for 2x Fuze SFX

Touring Case for 2x Fuze SFX

NEW



ELA0412

Touring Case for 2x Fuze SFX

Touring Case

Touring Case 1x Proteus Hybrid FI

Touring Case 1x Proteus Hybrid FI

NEW



ELA0408

Touring Case 1x Proteus Hybrid FI

Touring Case for 2x Smarty Hybrid FI

Touring Case for 2x Smarty Hybrid FI

NEW



Example only

ELA0413

Touring Case for 2x Smarty Hybrid FI

Touring Case for 2x Smarty MAX FI

Touring Case for 2x Smarty MAX FI

NEW



Example only

ELA0414

Touring Case for 2x Smarty MAX FI

Touring Case 4x DARTZ 360

Touring Case 4x DARTZ 360

NEW



Example only

ELA0409

Touring Case 4x DARTZ 360

Touring Case for 3 X Chorus Line 16

Touring Case for 3 X Chorus Line 16

NEW



Example only

ELA0415

Touring Case for 3 X Chorus Line 16

Touring Case for 2x Artiste Picasso

Touring Case for 2x Artiste Picasso

NEW



Example only

ELA0410

Touring Case for 2x Artiste Picasso

Touring Case for 3 X Chorus Line 8

Touring Case for 3 X Chorus Line 8

NEW



Example only

ELA0416

Touring Case for 3 X Chorus Line 8

Touring Case for 2x Artiste Picasso FI

Touring Case for 2x Artiste Picasso FI

NEW



Example only

ELA0411

Touring Case for 2x Artiste Picasso FI



Touring Case for 4 X DTW Blinder 700 IP

Touring Case for 4 X DTW Blinder 700 IP

NEW



Example only

ELA0417 Touring Case for 4 X DTW Blinder 700 IP

Seven Batten 14

The SEVEN BATTEN 14™ is a seven color 1.2 foot (0.4m) long batten wash luminaire with (12) 25W 7-in-1 RGBAW + Lime + UV (395nm) LEDs.



ELA0297 Seven Batten 14

Touring Case for 6 X Chorus Line 8

Touring Case for 6 X Chorus Line 8

NEW



Example only

ELA0418 Touring Case for 6 X Chorus Line 8

Seven Batten 42

The SEVEN BATTEN 42™ is a seven color 3.5 foot (1m) long batten wash luminaire with (36) 25W 7-in-1 RGBAW + Lime + UV (395nm) LEDs.



ELA0298 Seven Batten 42

Touring Case for 6 X DTW Blinder 350 IP

Touring Case for 6 X DTW Blinder 350 IP

NEW



Example only

ELA0419 Touring Case for 6 X DTW Blinder 350 IP

Seven Batten 72

The SEVEN BATTEN 72™ is a seven color 6 foot (1.8m) long batten wash luminaire with (60) 25W 7-in-1 RGBAW + Lime + UV (395nm) LEDs.



ELA0299 Seven Batten 72

Touring Case for 6 X DTW Blinder 700 IP

Touring Case for 6 X DTW Blinder 700 IP

NEW



Example only

ELA0420 Touring Case for 6 X DTW Blinder 700 IP

ZCL

ZCL Bar Z300IP

The ZCL BAR Z300 IP™ is a versatile IP65 rated bar effect luminaire with zoom, (5) individual 60W RGBW 4-in-1 LEDs, and the new advanced collimator optic lens which produces a sharp 4° color-changing beam from each lens.



ELA0422 ZCL BAR Z300IP

Seven

Seven Par 19IP

The SEVEN PAR 19IP™ is an IP65 outdoor rated seven color par wash luminaire with (19) 25W 7-in-1 RGBAW + Lime + UV LEDs (Red, Green, Blue, White, Amber, Lime, and a 395nm UV) producing up to 9,300 total output lumens and 90CRI.



ELA0300 Seven Par 19IP